

nunc®

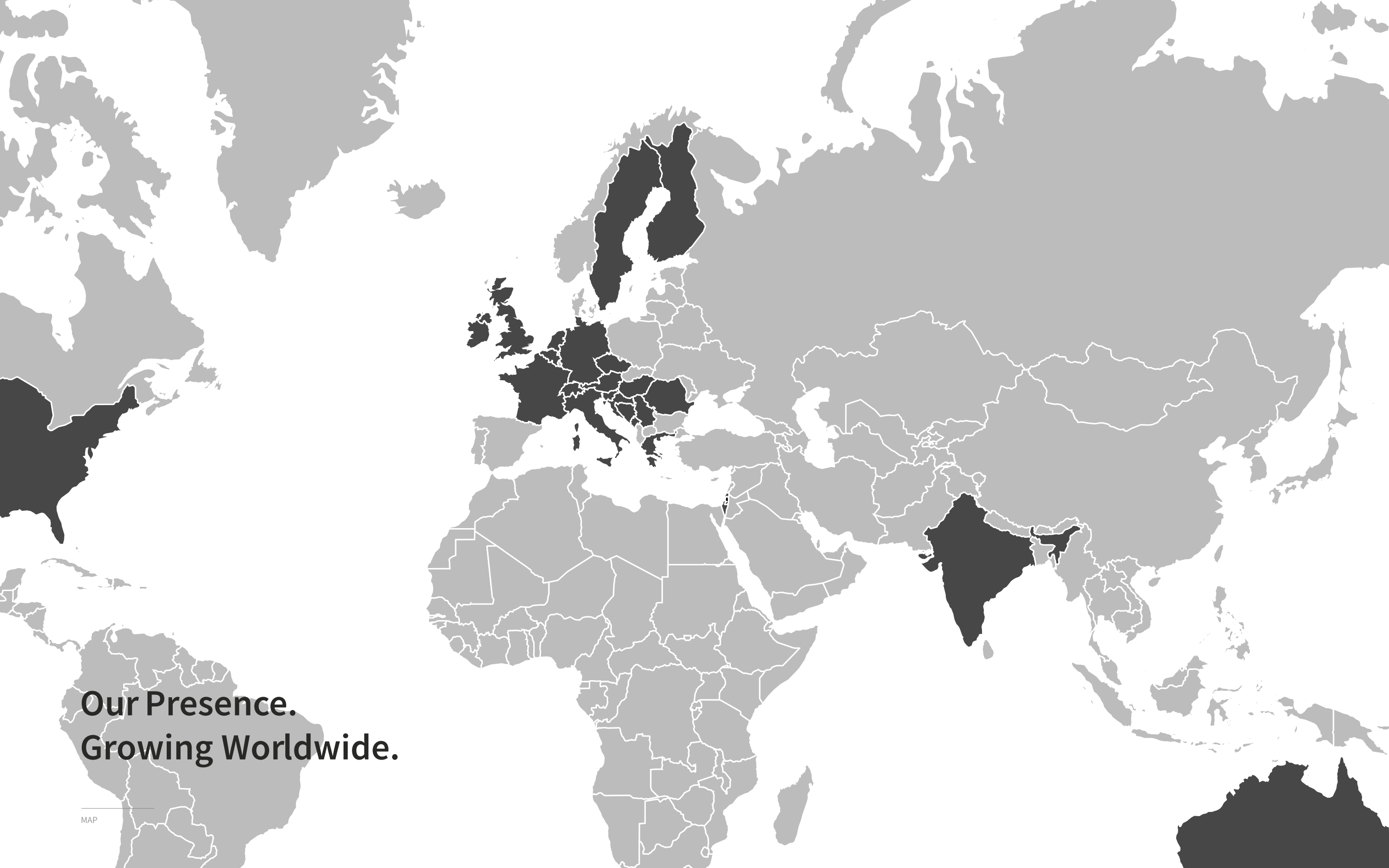

**Our Presence.
Growing Worldwide.**





"Let's see how we bring ideas to life"



Hotel Materra, located in Čepin, Croatia, and completed in 2023, presents a carefully designed interior furnished with selected pieces including Dika, Cot, Nauvik, and the Ruvo low table. These products contribute to the overall ambiance of the hotel, enhancing both its aesthetic quality and functional value. Conceived as a sanctuary of tranquility, the space combines contemporary design with comfort, creating a refined and inviting atmosphere for guests while supporting a range of everyday uses.

Hotel Materra

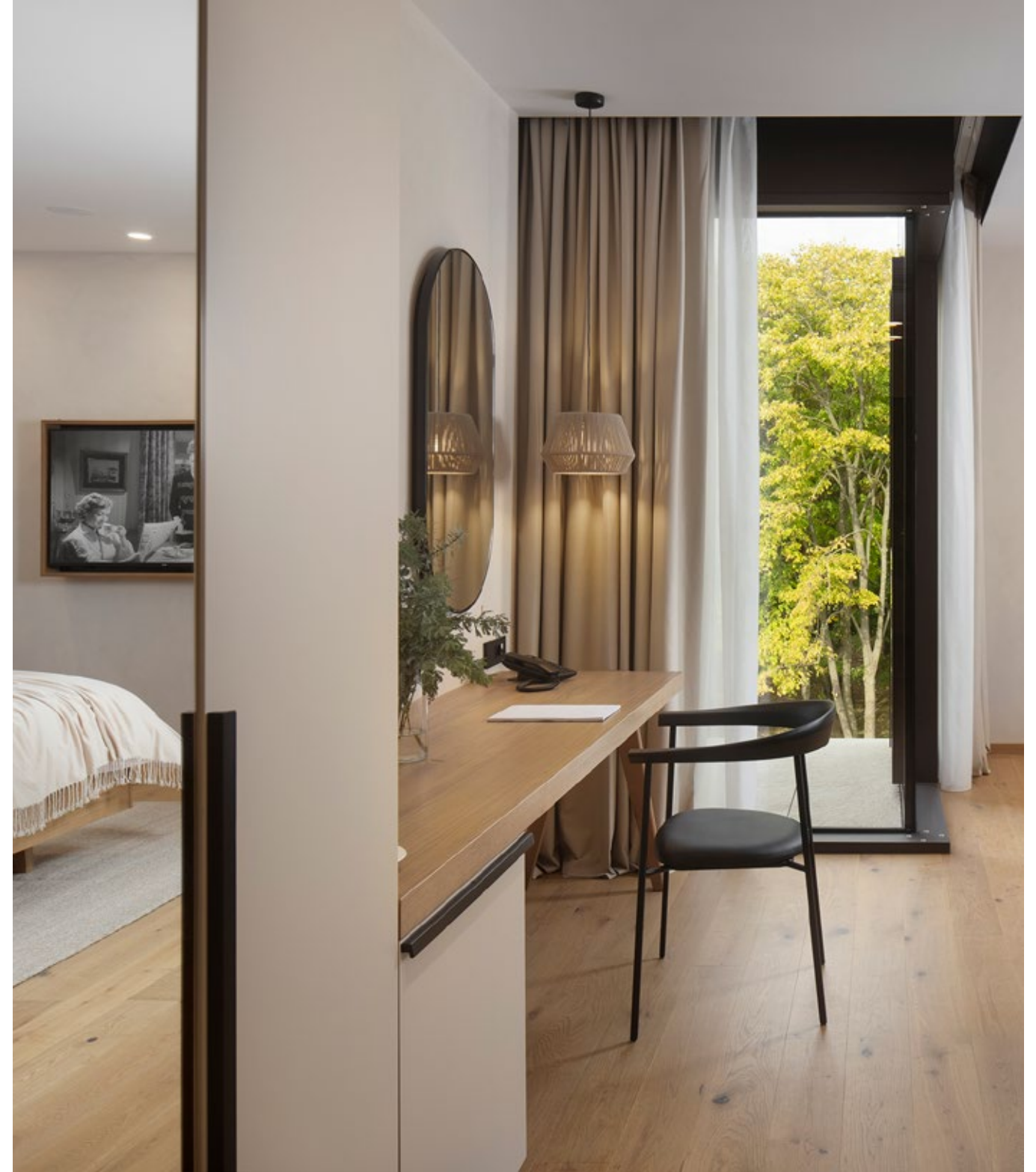



The interplay of materials and forms enhances functionality and aesthetics, expressed through clean lines, balanced proportions, and thoughtfully composed elements. The furniture integrates seamlessly into the interior, contributing to a sense of visual harmony and spatial clarity. This considered approach supports flexibility in use and reinforces the calm, cohesive character of the space, while maintaining a timeless and elegant design language throughout.









Located in Tar, on a plateau between Poreč and Novigrad, this project comprises the furnishing of 23 luxury villas with private pools, completed within a landscape defined by centuries-old olive groves and a rich cultural heritage. The villas offer a refined balance between the authenticity of the Istrian setting and the comfort of contemporary living.

Resort Taria

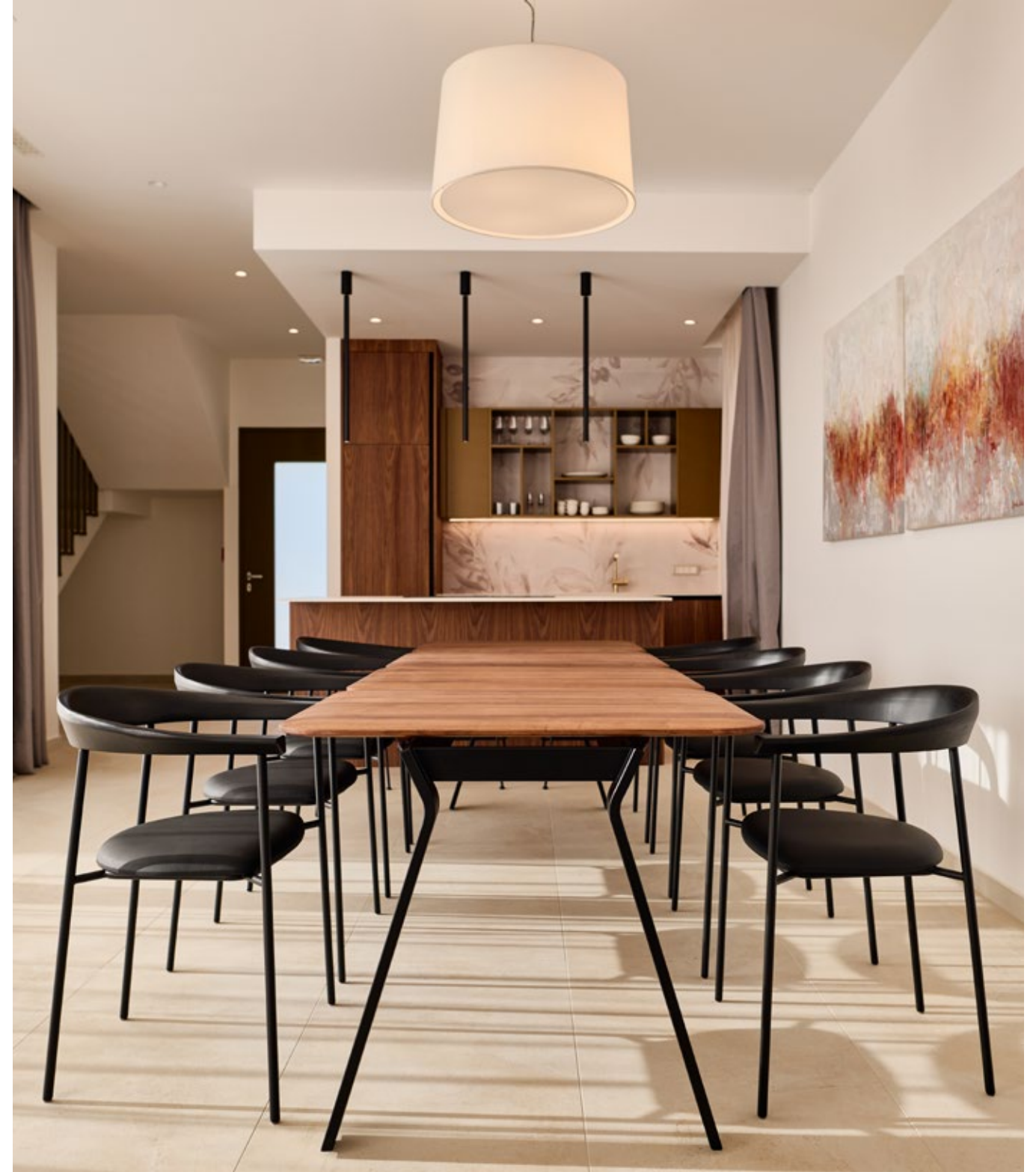



Particular attention was given to every detail, from the selection of furniture to the overall interior concept that complements the architectural language of the space. The furnishing includes the Nauvik chair, Cot chair, Dika armchair, and Tabure Skupa, alongside the Ala table and Ruvo low table, all carefully integrated to create a cohesive and harmonious interior expression.





The result is a collection of interiors that provide guests with a sophisticated, comfortable, and memorable stay. This project introduces a new dimension of luxury tourism in Istria, where nature and modern design come together in a harmonious and balanced experience.

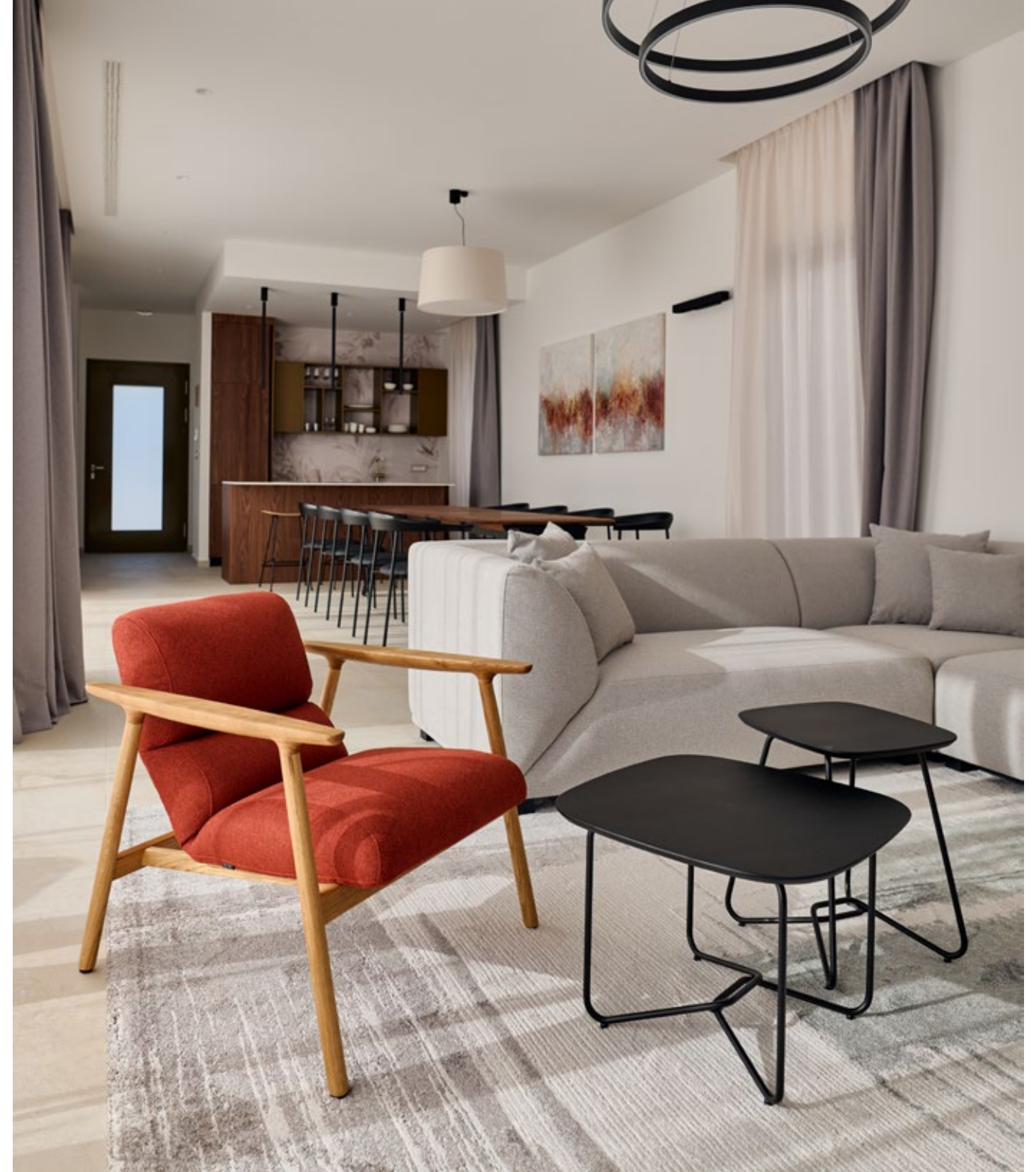



A workspace is defined as much by how it functions as by how it feels. For this office in Split, selected pieces from our collection were integrated into a carefully composed interior, supporting everyday work through proportion, comfort, and visual continuity.

The space is conceived to balance focused individual tasks with shared activities, creating an environment that feels both structured and relaxed, while maintaining a clear and consistent design language throughout.

Office UHY

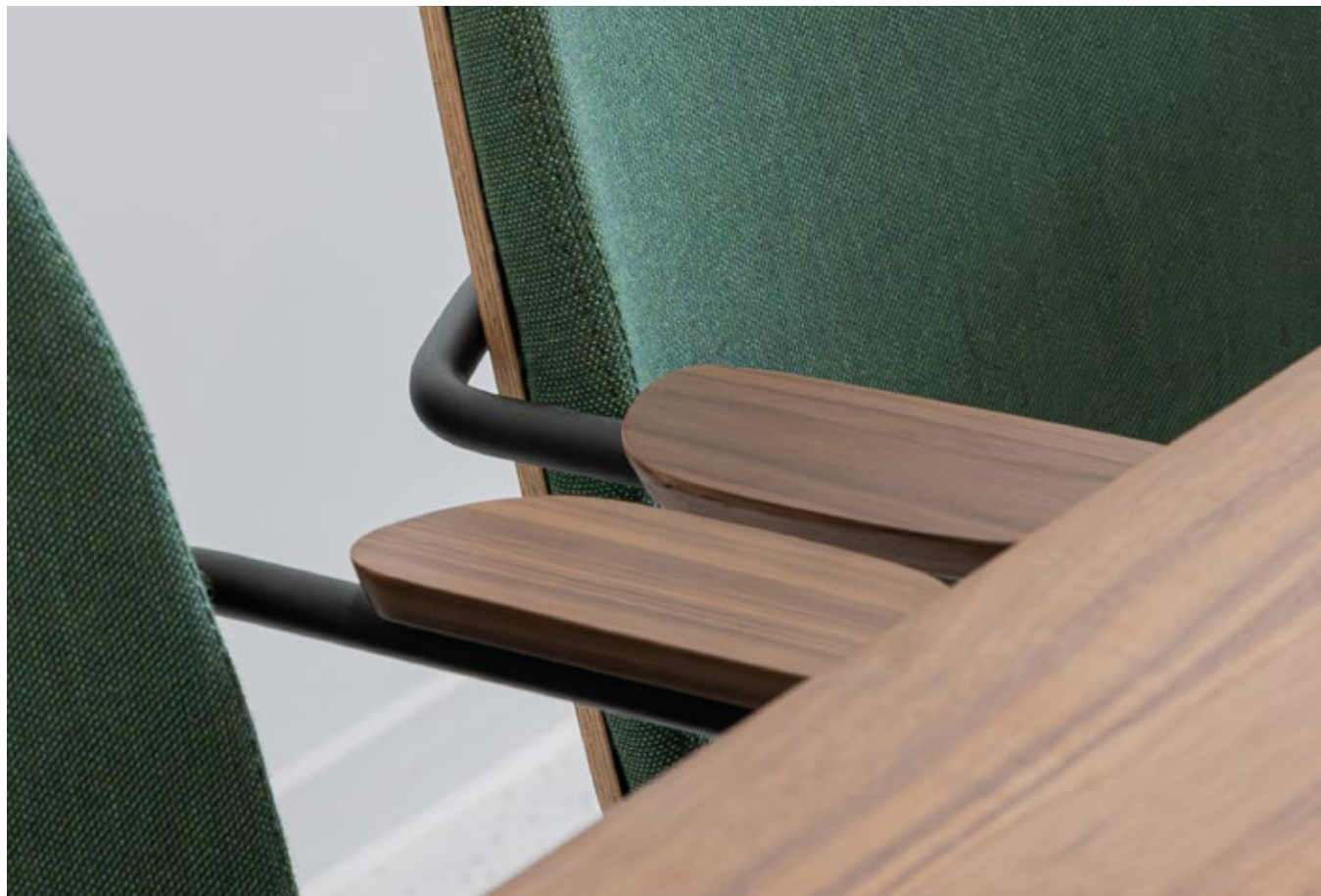

The office interior is furnished with Ala tables and Svib chairs, creating a cohesive and functional workspace. The design emphasizes both collaboration and individual focus, with furniture that supports everyday use through ergonomic comfort and visual consistency. This combination enhances shared areas, encourages informal interaction, and establishes a unified, contemporary atmosphere throughout the office.





The Dika armchair introduces a more relaxed and intimate dimension to the office environment, complementing the structured workspace with a sense of comfort and ease. Its warm materials and refined craftsmanship create a welcoming atmosphere, encouraging moments of pause and informal interaction. Integrated into the overall interior, it enriches spatial diversity while maintaining a consistent design language.

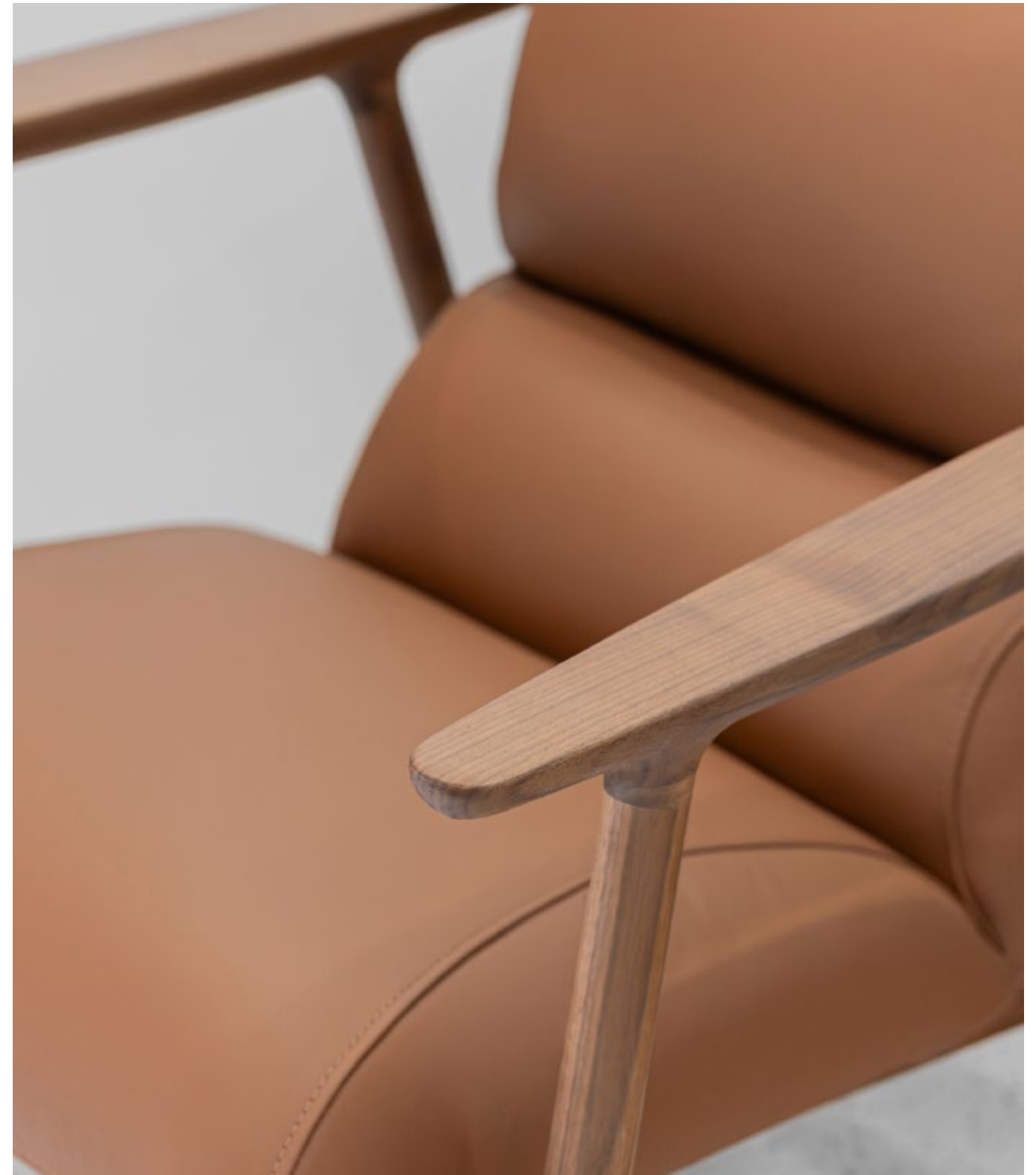





Bolta chairs, Ala tables, and Cot chairs work together to define a balanced and cohesive workspace. Their interplay of materials and forms supports both functionality and visual clarity, enabling smooth transitions between different areas of use. This combination enhances everyday usability while maintaining a calm, consistent, and thoughtfully articulated interior environment.



University of Rijeka



The University of Rijeka Innovalab is designed as a multifunctional pavilion for presentations, conferences, and workshops, supporting a range of activities through a clear and adaptable spatial setup. Bolta chairs are used throughout the interior, providing a consistent and practical seating solution, while their lightweight structure allows for easy reconfiguration. This approach ensures flexibility in use, encourages interaction, and maintains a functional and well-organized environment.



This office for Bruketa/Žinić/Grey is defined by a bold and immersive use of color, where a monochromatic pink environment creates a distinctive and cohesive spatial identity.

The interior is conceived as both a workspace and a meeting environment, supporting different modes of collaboration within a visually unified setting. Bolta chairs, finished in matching tones, are used throughout the space, reinforcing the overall concept while providing comfort and functionality in everyday use. Their form allows for flexible arrangements around meeting tables, adapting easily to different group sizes and working scenarios.

The continuous use of curtains softens the architecture, shaping the space while introducing a sense of depth and intimacy. This approach creates an atmosphere that is both expressive and controlled, where color, furniture, and spatial elements work together to support interaction, focus, and a dynamic working environment.

Bruketa/Žinić/Grey





Bakery Mlinar



Mlinar bakeries in Croatia are equipped with our Cot chairs, introducing a consistent seating element into everyday urban settings. This marks an important step and the beginning of a broader collaboration, bringing a locally designed product into familiar city environments. Designed in Slavonia and returned to everyday use, the chairs become part of daily routines, from a quick coffee to a short pause by the window. Their presence supports both functionality and comfort, fitting naturally into the rhythm of the bakery setting. This approach connects design with everyday use, creating a space that feels approachable, continuous, and well integrated into the life of the city which earned it the Red Dot design award in 2023.



Bakery Hleb & kifle





Bakery Hleb & kifle in Serbia is furnished with our Cot chairs, introducing a refined and consistent seating element into the interior. Their compact form and balanced proportions support everyday use, integrating naturally into the rhythm of the space. Positioned along counters and window areas, they accommodate both quick stops and quieter moments of pause. This considered placement enhances functionality while maintaining visual clarity and order. The chairs contribute to an atmosphere that feels both practical and composed, where movement, use, and spatial flow come together in a simple and cohesive way earning the chair the Red Dot design award in 2023.



Lounge bar Zona





Lounge bar Zona in Đakovo in the heart of Slavonia region, is conceived as a dynamic and inviting interior that balances everyday use with moments of social interaction. The space is organized through a variety of seating settings, from bar areas to more relaxed lounge zones, allowing it to adapt fluidly to different rhythms throughout the day. Ala tables are paired with Bolta, Cot, and Nauvik chairs, complemented by the Dika armchair, Ruvo low table, and Taraba, all carefully integrated into the overall composition.

Each element contributes through its form and material, creating a cohesive environment defined by clarity, comfort, and understated elegance.



Content

Cot	56
Cot Backrest	66
Cot Wood	70
Knap	76
Nauvik	82
Bolta	90
Bolta Lounge	98
Ruvo	104
Ruvo Jiha	110
Ruvo X	114
Svib	120
Dika	132
Mustra	138
Sechia	146
Ala	158
Ala Outdoor	166
Ala Office	176
Ala Conference	184
Ala Bar	192
Jaro bar & bistro	200
Ruvo	206
Kier collection	214
Sfumato	226
Aman Taman	234
Duja	240
Taraba	252
Eho	260
Kosir	266
Skupa	270
Materials	279
Designers	297

Cot
Cot Backrest
Cot Wood
Knap
Nauvik
Bolta
Bolta Lounge
Ruvo
Ruvo Jiha
Ruvo X
Svib
Dika
Mustra

Sechia

Ala
Ala Outdoor
Ala Office
Ala Conference
Ala Bar
Jaro bar & bistro
Ruvo

Kier collection

Sfumato
Aman Taman
Duja

Taraba
Eho
Kosir
Skupa

01 Chairs

BIGSEE
PRODUCTDESIGN
AWARD 2019
WINNER



Cot



The seamless interplay between form and function creates a dynamic yet timeless piece suited for contemporary interiors. Its slender yet sturdy structure, formed by an interwoven metal base, provides stability without compromising lightness, making it a refined addition to any space. From sophisticated bars and stylish kitchens to vibrant workspaces, Cot effortlessly adapts, adding a touch of elegance to every environment.





With its elegantly curved seat and precisely crafted metal frame, Cot redefines the aesthetics of modern seating. A balance of precision, comfort, and contemporary design, Cot is more than just a stool, it's an experience.



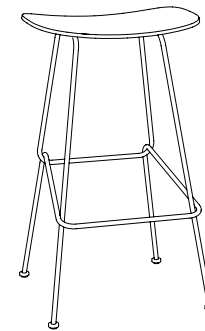

Cot

Designed for spontaneity and movement, Cot embodies the essence of modern living, whether for a quick coffee, a creative brainstorming session, or a moment of relaxation. The seat, available in natural wood or upholstered finishes, ensures ergonomic comfort while maintaining a sleek, minimalistic look.

CATEGORY Counter stool and barstool
SUITABILITY Indoor

TECHNICAL SPECIFICATIONS

SEAT / Am.walnut or oak veneer, matt acrylic lacquer or natural oil, with or without fabric or leather upholstery. Refer to materials guide for more information.

BASE / Matt powder coated steel bar

OPTIONS



seat without upholstery



seat with upholstery *

Counter stool



67 68 *

42

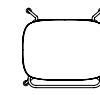

44

Bar stool



77 78 *

45



47



Cot Backrest



Engineered for comfort and support, the gently contoured backrest offers ergonomic benefits, while the spacious seat ensures a relaxed sitting experience. The sturdy metal legs are reinforced with crossbars that provide extra stability and double as a functional footrest. This thoughtful design makes it ideal for extended use.

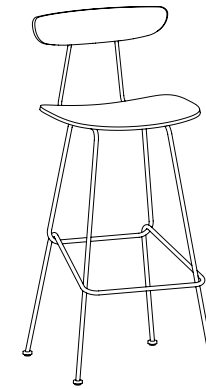

Counter stool with backrest

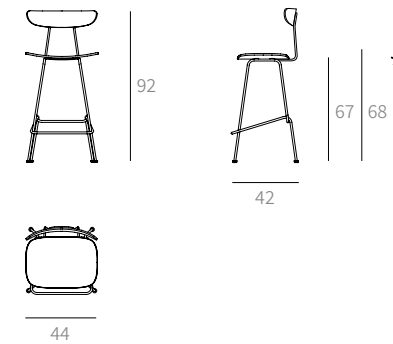

Bar stool with backrest

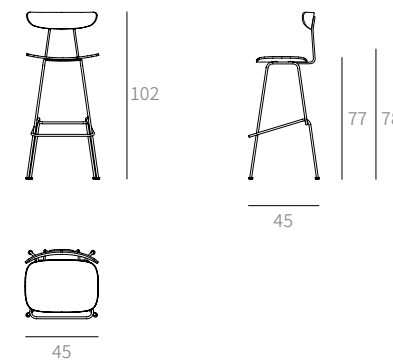

Cot Backrest

Perfect for kitchen islands, home bars, or commercial spaces, the Cot Bar Stool seamlessly complements a range of interior styles. Whether in a chic café, a stylish home, or an upscale restaurant, its seamless blend of wood and metal introduces elegance to any environment.

CATEGORY Stool and barstool
SUITABILITY Indoor

TECHNICAL SPECIFICATIONS

SEAT + BACKREST / Am.walnut or oak veneer, matt acrylic lacquer or natural oil, with or without fabric or leather upholstery. Refer to materials guide for more information.

BASE / Matt powder coated steel bars

OPTIONS

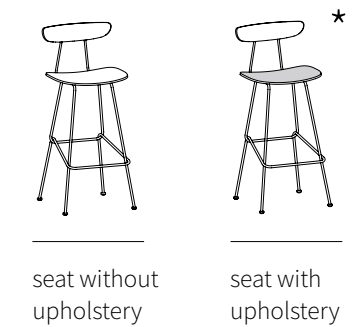



reddot winner 2023



Cot Wood





The Cot Wood chair showcases masterful craftsmanship and a refined aesthetic. Entirely constructed from natural wood, it radiates warmth and sophistication, making it an excellent choice for residential and commercial spaces.



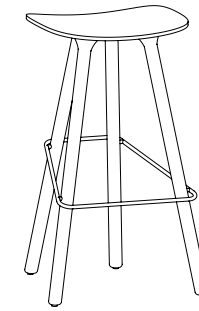

Cot Wood

A harmonious fusion of practicality and elegance, the Cot Wood chair effortlessly enhances any interior. Whether in a contemporary home or a stylish workspace, it introduces an element of natural charm and understated luxury.

CATEGORY Stool and barstool
SUITABILITY Indoor

TECHNICAL SPECIFICATIONS

SEAT / Am.walnut or oak solid wood, matt acrylic lacquer or natural oil, with or without fabric or leather upholstery. Refer to materials guide for more information.

BASE / Matt powder coated steel bars, solid oak or am. walnut, legs matt acrylic lacquer or natural oil

OPTIONS



Counter stool

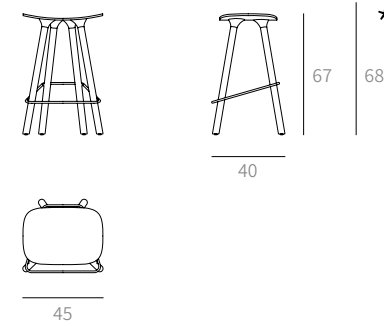

Bar stool

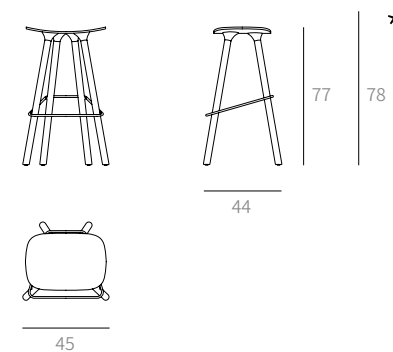



Knap







Knap

A refined balance of comfort and character, the Knap chair brings a distinctive presence to any interior. Its considered form and material expression create a sense of warmth and subtle sophistication, making it suitable for both residential and hospitality settings.

CATEGORY Chair
SUITABILITY Indoor

TECHNICAL SPECIFICATIONS

SEAT & BACKREST / am. walnut or oak veneer, with or without leather upholstery. Refer to materials guide for more information.

CONSTRUCTION / am. walnut or oak solid wood

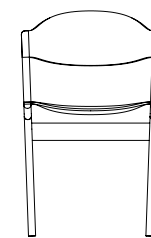
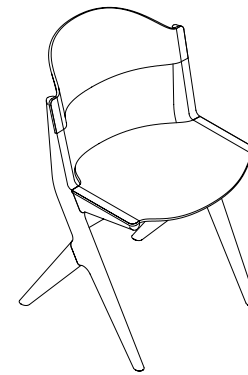

79

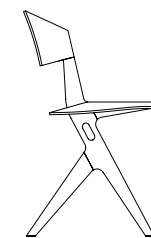

45,5

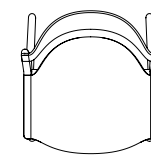

48,5

50



Nauvik





The ergonomic shape and comfortable seat provide excellent support and comfort, making it ideal for long periods at the table. Whether in the dining room, workspace, or lounge area, Nauvik's timeless design easily fits into any interior.

Crafted from high-quality materials, Nauvik ensures durability and stability, bringing reliability and style to any home or office. Available in various colours and finishes, the Nauvik chair adapts to every taste and style. Whether you're looking for an elegant addition to your dining room or a comfortable seat for your workspace, Nauvik is the perfect choice that combines aesthetics, comfort, and durability.





Nauvik

Nauvik Chair, the perfect blend of design and functionality! With its sleek lines, rounded backrest, and slim metal legs, it adds a touch of lightness and elegance to any space.

CATEGORY Dining chair
SUITABILITY Indoor

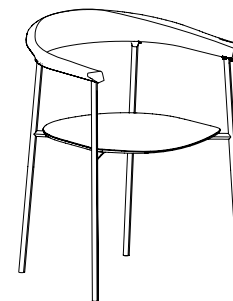

TECHNICAL SPECIFICATIONS

BACKREST / Solid wood, am.walnut or oak, matt acrylic lacquer or natural oil. Refer to materials guide for more information.

SEAT / Bent plywood, matt acrylic lacquer or natural oil, with fabric or leather upholstery.

BASE / Matt powder coated steel bars.

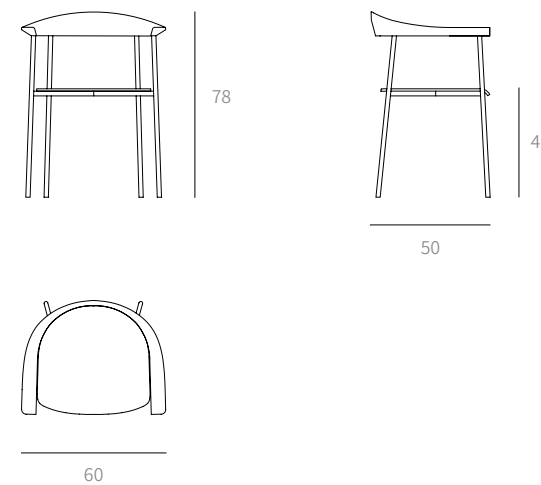

 BIGSEE
WOOD
AWARD 2019
WINNER



Bolta

DESIGN / Regular Company



COLLECTION / Chairs

Designed with vision and created for moments of relaxation, Bolta is much more than just a piece of furniture, it is a story woven from the past, present, and future.





The carefully crafted wooden elements bring silhouettes of bygone eras to life in the chair, where traditional aesthetics meet modern design. Through a play of materials and precise craftsmanship, every detail of Bolta exudes elegance and sophistication, creating a sense of connection to the past while embracing a bold vision of the future. The contrasting tones of cool metal do not stand in a piece of furniture, it is a story woven from the past, present, and future.



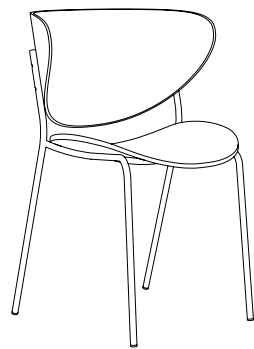

Bolta

Whether placed in modern interiors or environments inspired by the past, Bolta's presence adds a touch of sophistication and thoughtful design that transcends fleeting trends.

CATEGORY Conference, dining chair
SUITABILITY Indoor

TECHNICAL SPECIFICATIONS

SEAT + BACKREST / Am. walnut or oak veneer, matt acrylic varnish or natural oil, oak black stained or lacquered oak, with or without fabric or leather upholstery. Refer to materials guide for more information.

BASE / Matt powder coated steel bars

OPTIONS



seat without upholstery



seat with upholstery



seat and backrest with upholstery

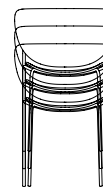

Stackable
(max 3pcs)

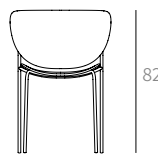

82



45

54

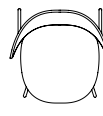

56



Bolta Lounge

When classic aesthetics meet modern thinking, the Bolta Lounge chair is born, a piece that not only catches the eye but also invites moments of relaxation. The expanded seat and gentle backrest recline provide casual comfort, while precisely shaped wooden elements and a stable metal frame ensure a balance of form and function.





Bolta Lounge

More than just an ordinary lounge chair, Bolta Lounge is a symbol of the fusion of past and future, a story told through details, materials, and impeccable craftsmanship. Designed with vision and created for those who recognize subtle luxury in simplicity.

CATEGORY Lounge chair
SUITABILITY Indoor

TECHNICAL SPECIFICATIONS

SEAT + BACKREST / Am. walnut or oak veneer, matt acrylic varnish or natural oil, oak black stained or lacquered oak, with or without fabric or leather upholstery. Refer to materials guide for more information.

BASE / Matt powder coated steel bars

OPTIONS



seat without upholstery



seat with upholstery



seat and backrest with upholstery

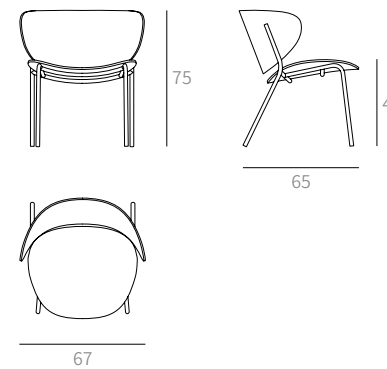



Ruvo





The fabrics that envelop the seat tell a story – gentle or bold, simple or luxurious, always tailored to the one who chooses them. Every thread, every layer contributes to the character, giving the seat a soul that breathes in the rhythm of the space. From warm, soft fabrics that evoke a sense of home to smooth, elegant coverings that reflect refined aesthetics, the possibilities are endless, just like the dreams woven on quiet evenings.



Ruvo

Metal legs, with thoughtfully shaped geometry, are both support and a visual dance. They tell a story of stability and lightness, of strength and elegance, blending with the space in quiet harmony. Their lines reflect balance, creating the impression that the seat floats while firmly grounding itself – like thoughts that wander but always return home.

CATEGORY Chairs
SUITABILITY Indoor

TECHNICAL SPECIFICATIONS

SEAT + BACKREST / Cold moulded foam. Fabric upholstery available. Refer to materials guide for more information.

BASE / Matt powder coated steel bars

Regular base

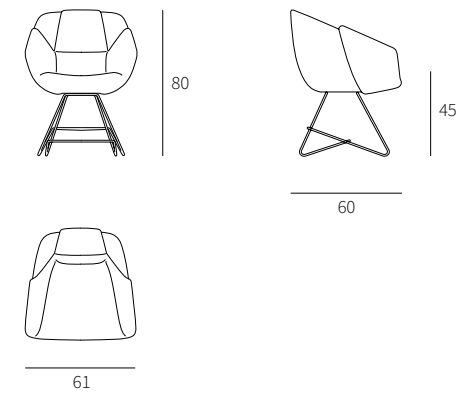

Counter base

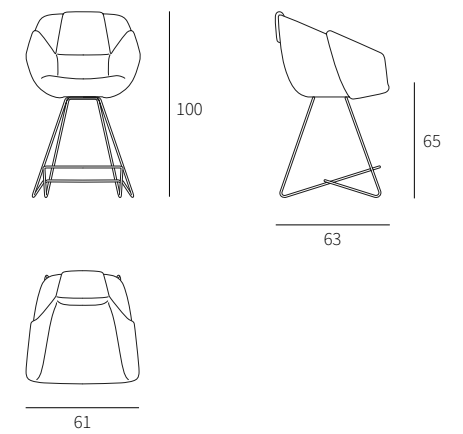



Ruvo Jiha





Carefully crafted to provide a sense of security and lightness, the Ruvo Jiha chair adapts to the body, offering exceptional comfort. The seat, wrapped in soft and breathable fabric, is filled with layers of comfort that ensure optimal support. Whether you're enjoying a moment of peace with a book, sipping your favourite drink, or indulging in gentle rocking, it offers a flawless relaxation experience.

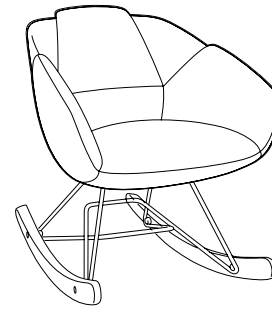

Ruvo Jiha

A sturdy metal frame paired with graceful wooden rockers strikes a perfect harmony between modern aesthetics and natural warmth. The minimalist lines of the base contribute to visual lightness, while carefully selected materials bring harmony and sophistication to any interior.

CATEGORY Easy rocking chair
SUITABILITY Indoor

TECHNICAL SPECIFICATIONS

SEAT + BACKREST / Moulded foam. Fabric upholstery available. Refer to materials guide for more information.

BASE / Matt powder coated steel bars and solid wood

Swivel base

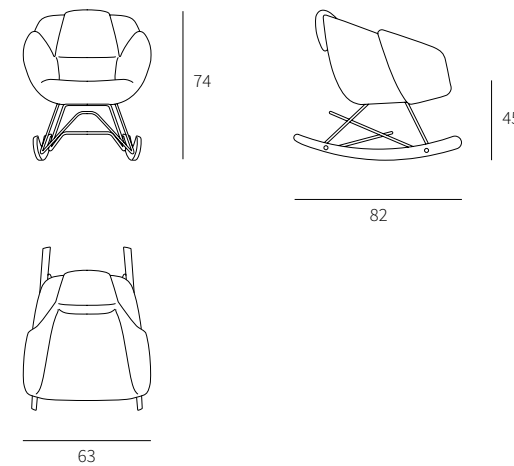

 **BIGSEE**
PRODUCTDESIGN
AWARD 2019
WINNER



Ruvo X

DESIGN / Vladimir Madunić ABC Design

114



COLLECTION / Chairs

115



Designed for those who seek comfort and sophistication, Ruvo X transforms everyday seating into an experience of effortless support and refined aesthetics. Its plush, nest-like cushioning, crafted from high-quality cold foam, gently conforms to the body, making long hours at a desk feel light and natural. Whether in a modern office, a conference room, or a home workspace, Ruvo X seamlessly adapts, offering a perfect balance of relaxation and focus.



Ruvo X

More than just a chair, Ruvo X is a canvas for expression. Tailored to fit any space, subtle and understated or bold and striking. Soft, textured materials invite warmth, while sleek, sophisticated finishes create a contemporary statement.

CATEGORY Conference chair

SUITABILITY Indoor



TECHNICAL SPECIFICATIONS

SEAT + BACKREST / Moulded foam. Fabric upholstery available. Refer to materials guide for more information.

BASE / Matt powder coated steel bars

X base

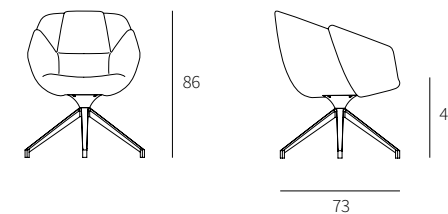

Rotateable **180°**





Svib







Designed with form and function in mind, Svib's ergonomic structure ensures maximum comfort during long hours of use. Whether you're working from home or in an office, its timeless design and high-quality materials make it an ideal partner for remote and office jobs, blending elegance and simplicity effortlessly.

The combination of metal armrests accentuated by oak veneers and a rotating chair leg construction offers a balanced feel that fits seamlessly into traditional and contemporary settings. The sleek metal armrests add a modern touch, while the oak veneers bring warmth and natural elegance, making Svib a versatile piece for any environment.



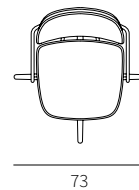
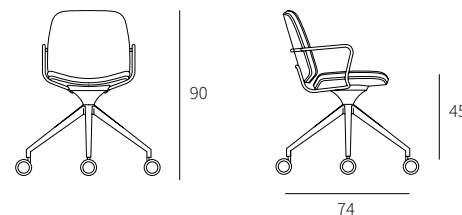
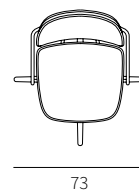
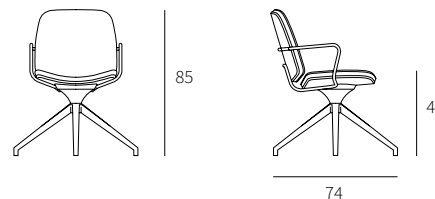

Svib

Svib provides stability and comfort, much like the flowering shrub named after. Just as the shrub's powerful roots anchor it firmly while its flowers reach the sky, Svib's sturdy metal base supports two symmetrical shells, creating a perfect harmony between function and aesthetics.

CATEGORY Office chair

SUITABILITY Indoor

TECHNICAL SPECIFICATIONS

SEAT + BACKREST / Am.walnut or oak veneer, moulded foam, matt acrylic lacquer or natural oil. Fabric or leather upholstery. Refer to materials guide for more information.

OPTIONS



optional wheels



optional wooden armrest



rotateable **180°**





Dika



Dika is a contemporary take on a traditional armchair inspired by the Danish design from the mid-60s, whose name roughly translated means pride in the Slavonian dialect. Simple wordplay conceived by a designer from the region and made from locally sourced wood is the essence of Nuncs' brand promise, blending exceptional craftsmanship with modern technology. The armchair's design plays between curved and straight lines, creating a harmonious balance that is both visually appealing and structurally sound.





Attention to detail and the distinctive break in the lumbar area make Dika a comfortable yet elegant component of any public space or home environment. The soft and rounded solid wood pays beautiful homage to the comfortable foam seat, which is integrated with a cold steel construction that provides essential support. This combination ensures that the armchair is stylish but also durable and supportive, making it suitable for long sitting periods.

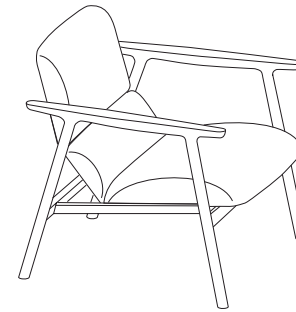

Dika

The silhouette of Dika, which has been modified and brought back, evokes a sense of nostalgia while maintaining a modern aesthetic. This blend of old and new makes it a versatile piece that can complement various interior styles. Whether placed in a living room, office, or lounge area, Dika stands out as a testament to the enduring appeal of mid-century design, reimagined for contemporary settings.

CATEGORY Armchair
SUITABILITY Indoor

TECHNICAL SPECIFICATIONS

SEAT / Fabric or leather upholstery. Refer to materials guide for more information.

BASE / Am. walnut or oak solid wood, matt acrylic varnish or natural oil

SUB-CONSTRUCTION / Sponge integrated with steel structure

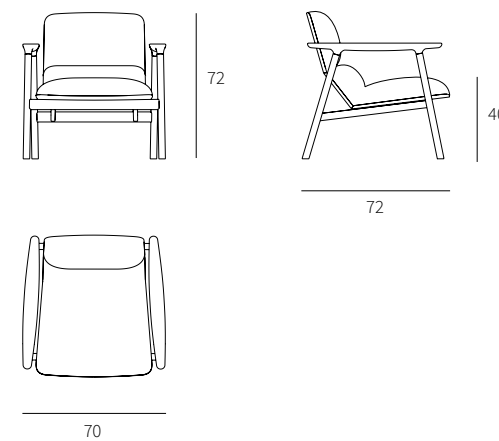



As its name suggests, *Mustra* carries multiple meanings depending on the region. It describes an unpredictable free spirit, a clever trickster, or a fabric pattern. This duality reflects the chair's versatility: refined yet daring, structured yet playful. Its carefully designed curves follow the body's contours, ensuring a comfortable seating experience without unnecessary bulk. This balance between minimalism and comfort makes it an inviting addition to any space.

Mustra





Inspired by adaptability and individuality, the Mustra Chair captures form and function in a strikingly minimal design. Constructed from durable metal rods its fluid structure offers a sense of lightness while ensuring exceptional strength. The chair's airy yet sturdy frame provides ergonomic comfort, making it a perfect choice for various settings, from contemporary dining spaces to stylish outdoor lounges. Its clean, modern aesthetic allows it to blend effortlessly into different interiors while maintaining a bold, independent character.



Mustra

Beyond its practicality, the Mustra Chair serves as a design statement, subtle yet striking. Whether used alone or as part of a set, it brings a unique personality to any environment. Mustra is more than just a chair; it's a presence, a pattern, and a story.

CATEGORY Garden chair
SUITABILITY Outdoor

TECHNICAL SPECIFICATIONS

SEAT + BACKREST + BASE / Matt galvanized and matt powder coated steel bars. Refer to materials guide for more information.

OPTIONS



cushion

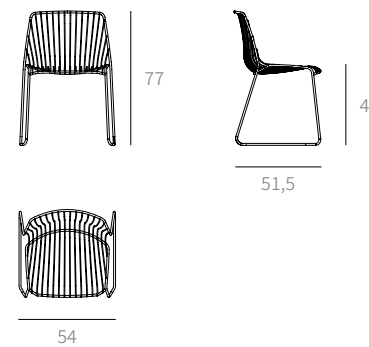

Cot
Cot Backrest
Cot Wood
Knap
Nauvik
Bolta
Bolta Lounge
Ruvo
Ruvo Jiha
Ruvo X
Svib
Dika
Mustra

Sechia

Ala
Ala Outdoor
Ala Office
Ala Conference
Ala Bar
Jaro bar & bistro
Ruvo

Kier collection

Sfumato
Aman Taman
Duja

Taraba
Eho
Kosir
Skupa

02

Sofas



The Sechia sofa combines modern design with everyday functionality. Its low-profile frame and deep seating provide a comfortable and inviting lounging experience, while the soft fabric upholstery adds warmth to any space. The clean lines make it easy to integrate into various interior styles.

Sechia







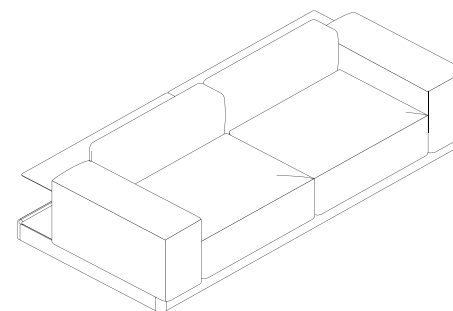

3 seater EXTENDED



2 seater EXTENDED

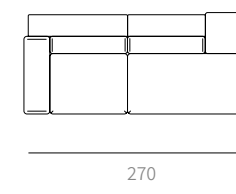

3 seater

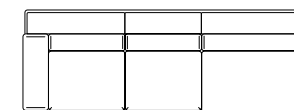
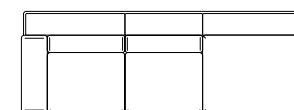
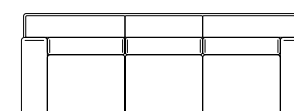

330

2 seater

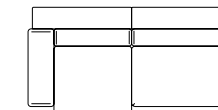
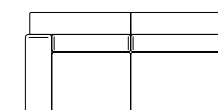
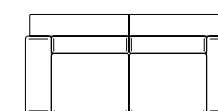

240

Sechia

Crafted with a sturdy wooden base and high-quality materials, the Sechia sofa is designed for long-lasting comfort and durability. Whether used for relaxing, entertaining, or organizing your space, it provides a versatile solution for modern living.

CATEGORY Modular sofa

SUITABILITY Indoor

TECHNICAL SPECIFICATIONS

SEAT, BACKREST, ARMREST / Am. walnut or oak solid wood, matt acrylic varnish or natural oil. Upholstered sponge, fabric or leather. Refer to materials guide for more information.

BASE / Am. walnut or oak solid wood, matt acrylic varnish or natural oil. Refer to materials guide for more information.

SHELF / Powder-coated steel

CRATE / Plywood or oak veneer, matt acrylic varnish or natural oil. Refer to materials guide for more information.

OPTIONS

Armrest: left/right

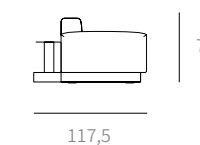
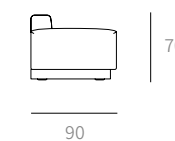



A key feature of Sechia is its built-in rear shelving, offering practical storage for books, decorative items, or everyday essentials. This thoughtful addition enhances both the aesthetic appeal and usability of the sofa, making it well-suited for open-concept spaces or multifunctional living areas.



Cot
Cot Backrest
Cot Wood
Knap
Nauvik
Bolta
Bolta Lounge
Ruvo
Ruvo Jiha
Ruvo X
Svib
Dika
Mustra

Sechia

Ala
Ala Outdoor
Ala Office
Ala Conference
Ala Bar
Jaro bar & bistro
Ruvo

Kier collection

Sfumato
Aman Taman
Duja

Taraba
Eho
Kosir
Skupa

03

Tables



Golden Key Award



GERMAN DESIGN AWARD SPECIAL 2021



BIGSEE WOOD AWARD 2019 WINNER



IDA 2019 BRONZE WINNER



Ala



Ala is more than just a table, it's a dynamic centrepiece designed to adapt to any occasion. Its modular design features sliding wooden plates that break away from traditional tabletop aesthetics, offering a fresh perspective on form and function. Seamlessly integrated storage compartments bring practicality and elegance together in one refined piece.

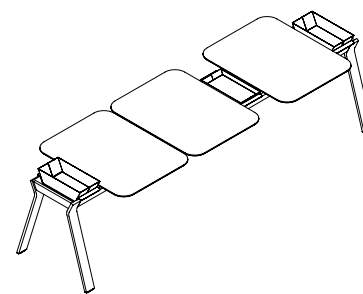

Ala

Beyond its striking design, Ala redefines the way we interact with furniture. Its innovative sliding mechanism invites customization, enabling users to shape their table according to the moment. Ala is a statement of versatility and sophistication.

CATEGORY Dining table
SUITABILITY Indoor

TECHNICAL SPECIFICATIONS

TABLETOP / Am. walnut or oak solid wood, matt acrylic varnish or natural oil. Matt powder coated steel containers. Refer to materials guide for more information.

BASE / Matt powder coated steel bars

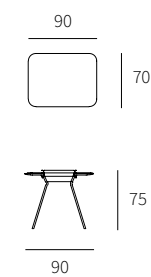

Mini 2p

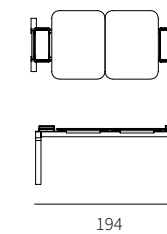

Small 3p

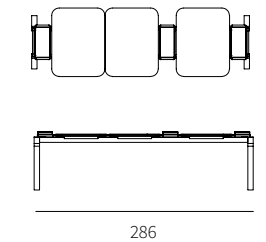

Regular 4p

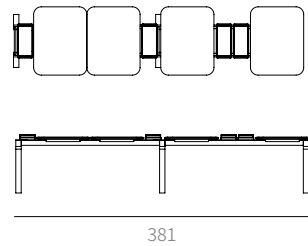

Ext. 5p

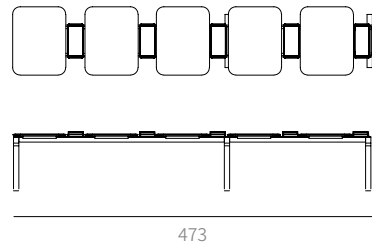

Large 6p

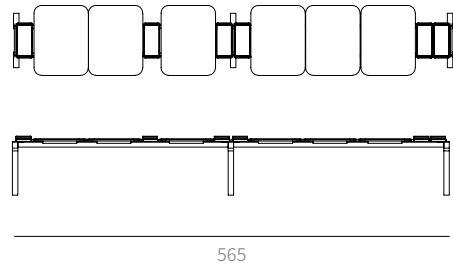

XL 7p

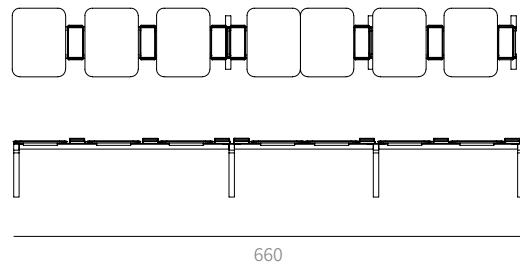

XXL 8p

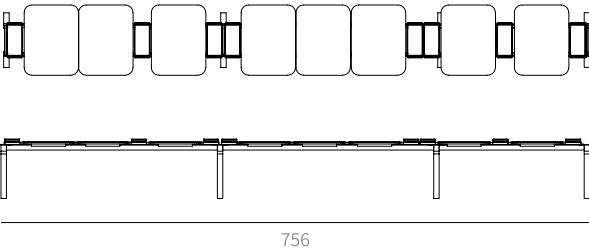

XXL 9p

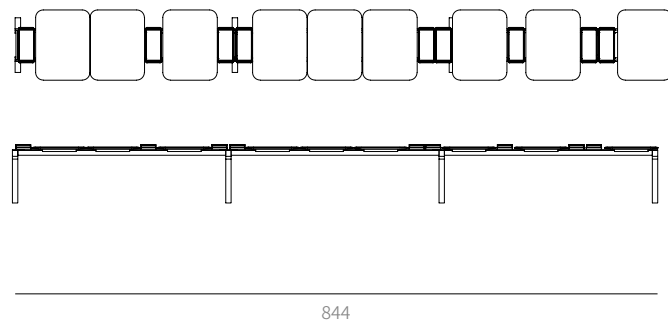

Fully adjustable in width, Ala transforms effortlessly to accommodate different needs. Whether hosting an intimate dinner or a lively gathering, its flexible structure allows quick adjustments, ensuring a perfect balance between space and convenience. The interplay between warm wood tones and sleek metal elements enhances any setting, from modern interiors to outdoor lounges.



The table's signature modular design includes integrated storage compartments, perfect for keeping essentials like condiments, plants, or decorative elements within reach.

Ala Outdoor







Crafted for resilience, the Ala Outdoor Table features a weather-resistant construction that withstands the elements without compromising style. The combination of a robust metal frame and high-quality tabletop materials ensures longevity, making it a versatile choice for gardens, terraces, patios, or hospitality spaces. Its refined structure maintains a sense of lightness while providing a stable and inviting surface for dining, working, or socializing.

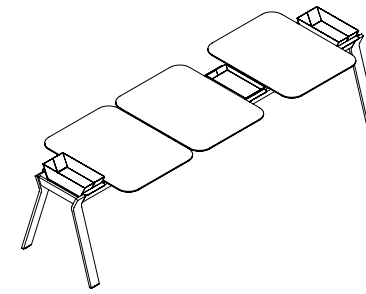

Ala outdoor

The Ala Outdoor Table is designed to bring people together in open-air settings, blending architectural elegance with durable functionality. Its clean, elongated form redefines outdoor dining, offering practicality and aesthetic appeal.

CATEGORY Outdoor table
SUITABILITY Outdoor

TECHNICAL SPECIFICATIONS

TABLETOP / Compact plates. Matt powder coated steel containers. Refer to materials guide for more information.

BASE / Matt galvanized and matt powder coated steel bars

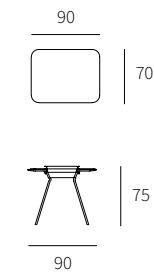

Mini 2p

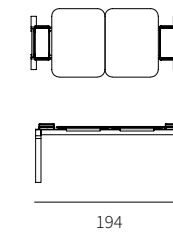

Small 3p

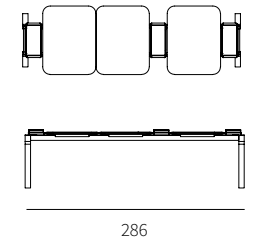

Regular 4p

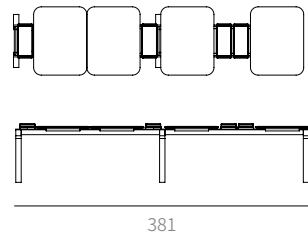

Ext. 5p

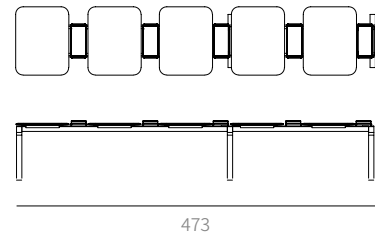

Large 6p

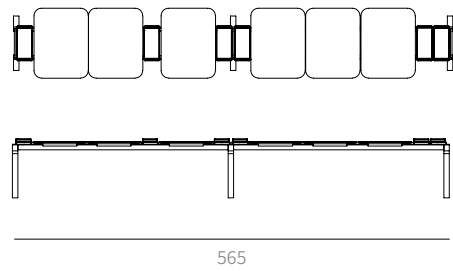

XL 7p

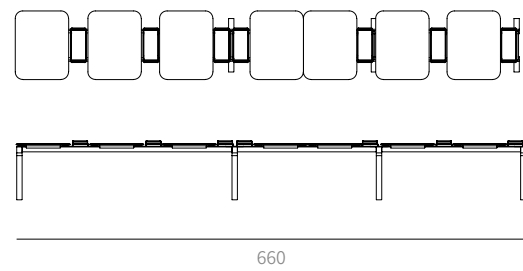

XXL 8p

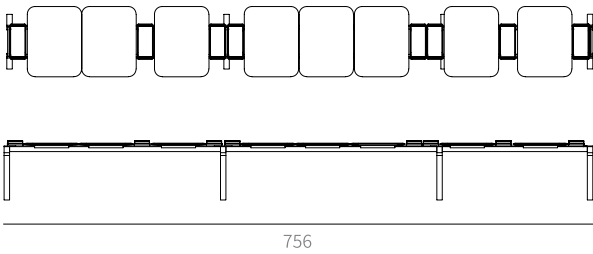

XXL 9p

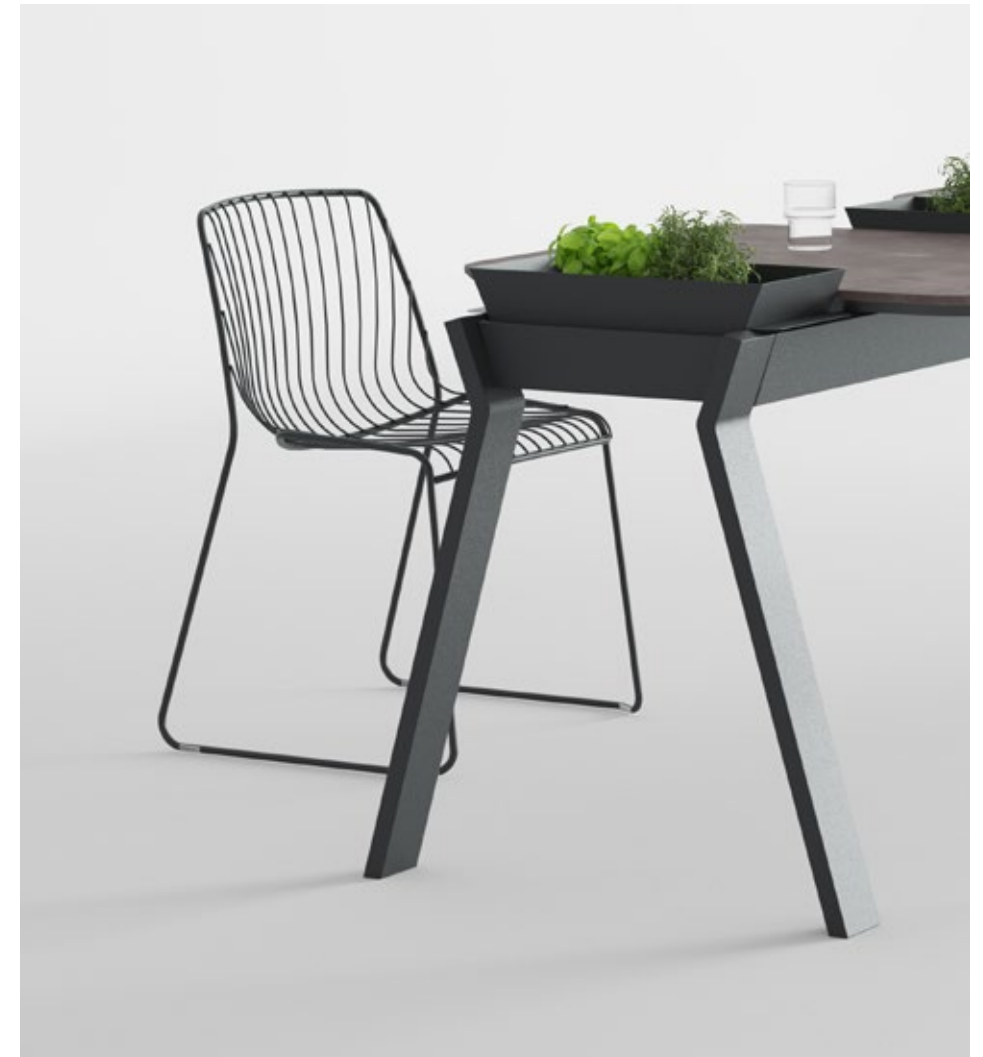
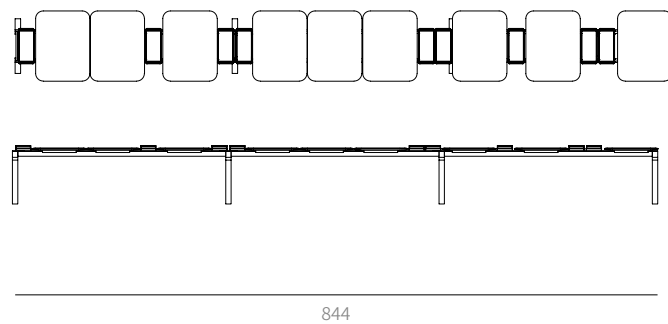

Beyond its functionality, the Ala Outdoor Table transforms outdoor space into a dynamic and welcoming environment. Whether hosting a lively gathering or creating a serene retreat, its adaptable nature allows it to fit seamlessly into various settings. A statement piece in its own right, it elevates the experience of open-air living, merging comfort, design, and durability in perfect harmony.





Details such as cable covers on the table plates facilitate efficient cable management, creating an agile and organized workspace, an essential feature of contemporary offices.

Ala Office



The Ala table divider, also part of the Ala tables collection, is specifically designed for office environments. Constructed with plywood and a spongy core, and upholstered in fabric, the divider not only separates spaces but also provides privacy and sound insulation, both crucial in busy office settings.



Together, these elements of the Ala collection offer a perfect blend of practicality and sophistication, ensuring that office spaces are both functional and aesthetically pleasing. Whether in individual workstations or collaborative areas, the Office Ala and its accompanying divider contribute to a well-organized and efficient workspace.



Ala Office

The Office Ala has been designed to enhance workspaces. Intended for one-sided seating, it is a modern, functional, and robust addition to any office. Its dimensions and number of plates are customizable to meet users' specific requirements.

CATEGORY Office table
SUITABILITY Indoor

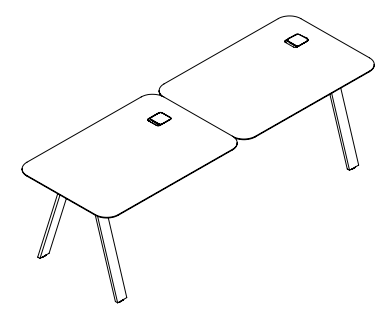

PAIRS WITH...

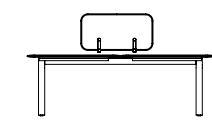
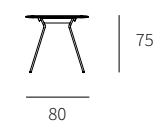

Ala Office divider

TECHNICAL SPECIFICATIONS

TABLETOP / Fenix. Refer to materials guide for more information.

BASE / Matt powder coated steel bars

1p 120x80

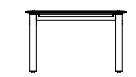
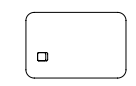

120

1p 140x80

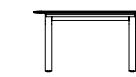
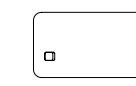

140

1p 160x80

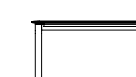
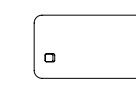

160

1p 180x80

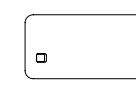

180

1p 200x80



200

2p 240x80

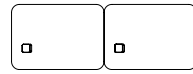

240

2p 280x80

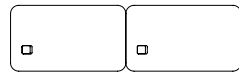

280

2p 320x80

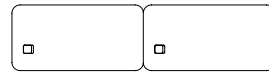

600

2p 360x80

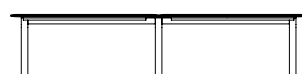
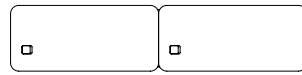

360

2p 400x80

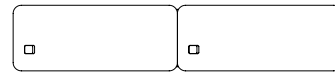

400





Ala Conference





In addition to its impressive structural integrity, it is equipped with thoughtful details, such as cable covers on the table plates. These features facilitate efficient cable management, creating a streamlined and organized workspace. This attention to detail helps maintain a clutter-free environment, enhancing productivity and focus during important meetings.

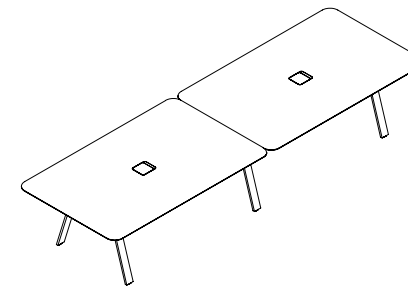

Ala Conference

This table is an indispensable asset in the fast-paced business world. Its design supports agile decision-making and decisive actions, providing a reliable and sophisticated platform for collaboration. Whether in a corporate boardroom or a dynamic office setting, it elevates the standard of professional furniture with its practicality and elegance.

CATEGORY Conference table
SUITABILITY Indoor

TECHNICAL SPECIFICATIONS

TABLETOP / Fenix, am. walnut or oak solid wood, matt acrylic varnish or natural oil. Refer to materials guide for more information.

BASE / Matt powder coated steel bars

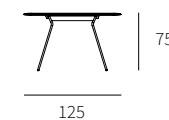

1p 160x125

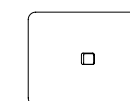

160

1p 200x125

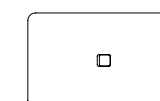

200

2p 320x125



320

2p 400x125

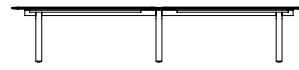
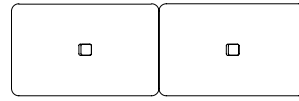

400

3p 480x125

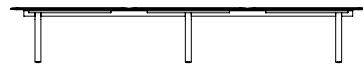
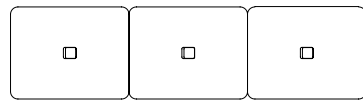

480

3p 600x125

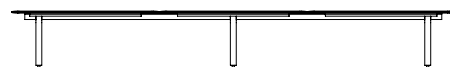
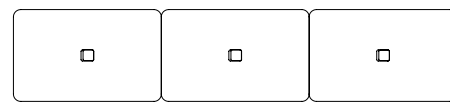

600





Ala Bar





The Ala Bar Table redefines high-table functionality with a refined yet dynamic presence. Elevated on sturdy legs, its sleek tabletop provides an inviting space for collaboration, conversation, or quiet focus. Whether used in offices, cafés, or creative hubs, its clean lines and natural materials create a perfect balance between practicality and aesthetics.

Designed to adapt, the Ala Bar Table is available in various dimensions and finishes, seamlessly blending into diverse interiors. Solid wood and metal elements ensure durability while maintaining a light, airy feel. With an emphasis on ergonomics, its height promotes movement, making it an excellent choice for standing discussions and seated interactions with bar stools.



Ala Bar

More than just a surface, the Ala Bar Table becomes a gathering point, a place where ideas flow, and connections are made. Its minimalist yet warm design transforms any setting into a welcoming, agile workspace or social hub, proving that great design is as much about experience as it is about form.

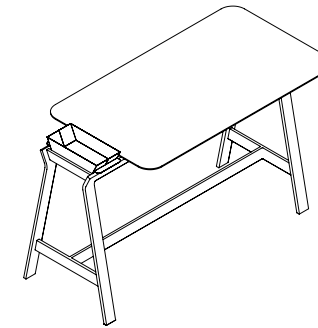

CATEGORY Bar table
SUITABILITY Indoor

TECHNICAL SPECIFICATIONS

TABLETOP / Am. walnut or oak solid wood, matt acrylic varnish or natural oil. Matt powder coated steel containers. Refer to materials guide for more information.

BASE / Matt powder coated steel bars

DIFFERENT HEIGHT OPTIONS

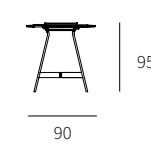
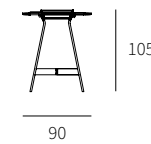

Ala Bar 2p

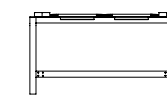
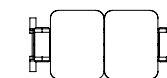

195

Ala Bar 3p

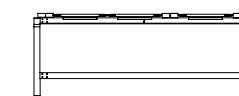
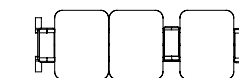

287

Ala Bar 1600x900

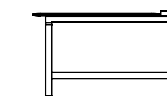
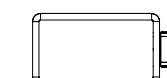

187

Ala Bar 2000x900

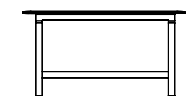
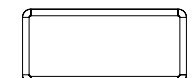

200

The Ala semi-bar table brings the same refined functionality as its taller counterpart, now in a versatile mid-height version. Designed to adjust between standing engagement and seated comfort, it creates an inviting space for collaboration, casual meetings, or moments of quiet focus. Its sleek lines and natural materials make it a seamless addition to offices, cafés, and dynamic workspaces.

Crafted from solid wood and metal, it ensures durability while maintaining a light, modern aesthetic. Its thoughtfully designed height accommodates a range of seating options, making it an excellent choice for relaxed discussions, brainstorming sessions, or informal dining experiences.

More than just a functional surface, this semi-bar table can be a central point. With its ergonomic proportions and timeless design, Ala transforms spaces into flexible, welcoming environments, proving that practicality and style go hand in hand.





Jaro

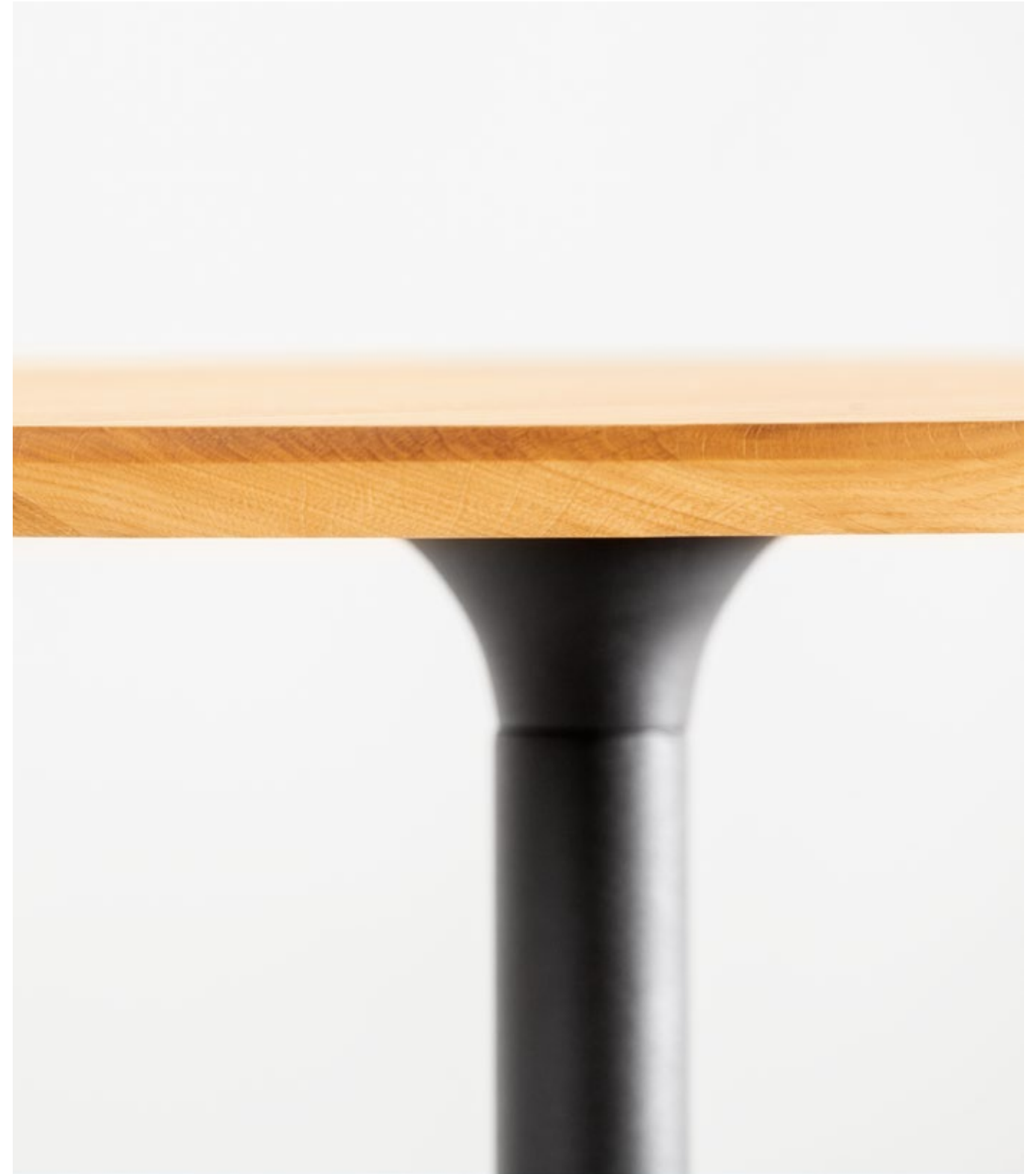



The tabletop can be crafted from various high-quality materials, including solid oak, American walnut, compact laminate, or innovative Fenix, known for its matte, fingerprint-resistant, and scratch-resistant surface.



Jaro, derived from the Turkish-Persian word Yar, meaning “friend” (a term commonly used in Slavonia), is a collection of tables and bar tables designed to focus on functionality and contemporary aesthetics. Its distinctive feature is the circular central base, made of powder-coated steel plate and tube, ensuring stability while maintaining a visually light appearance. A conical connecting element seamlessly joins the base components, adding a touch of elegance while enhancing structural integrity and durability.

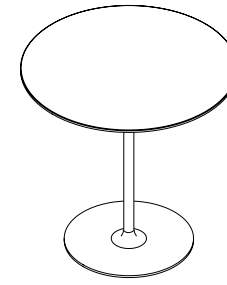

Jaro

BAR, SEMIBAR
& BISTRO

With different tabletop sizes and base heights, Jaro offers remarkable versatility, making it suitable for diverse settings such as cosy café corners, upscale restaurant interiors, or stylish bar environments. The adaptability of this collection allows for the creation of dynamic setups that complement various interior styles.

CATEGORY Bar, semibar and bistro table
SUITABILITY Indoor

TECHNICAL SPECIFICATIONS

TABLETOP / Compact or oak solid wood, matt acrylic varnish or natural oil. Refer to materials guide for more information.

BASE / Matt powder coated steel plate and tube

Bar

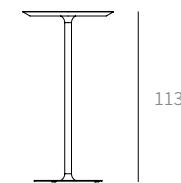

113

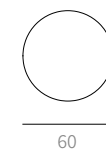

60

Bistro

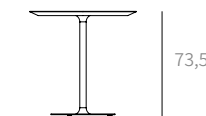

73,5

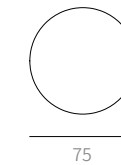

75

Semi Bar

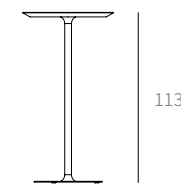

113



60

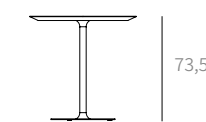

73,5



75

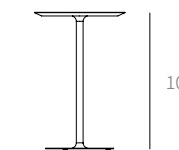

105

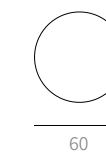

60

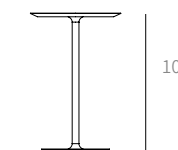

105



60



Ruvo

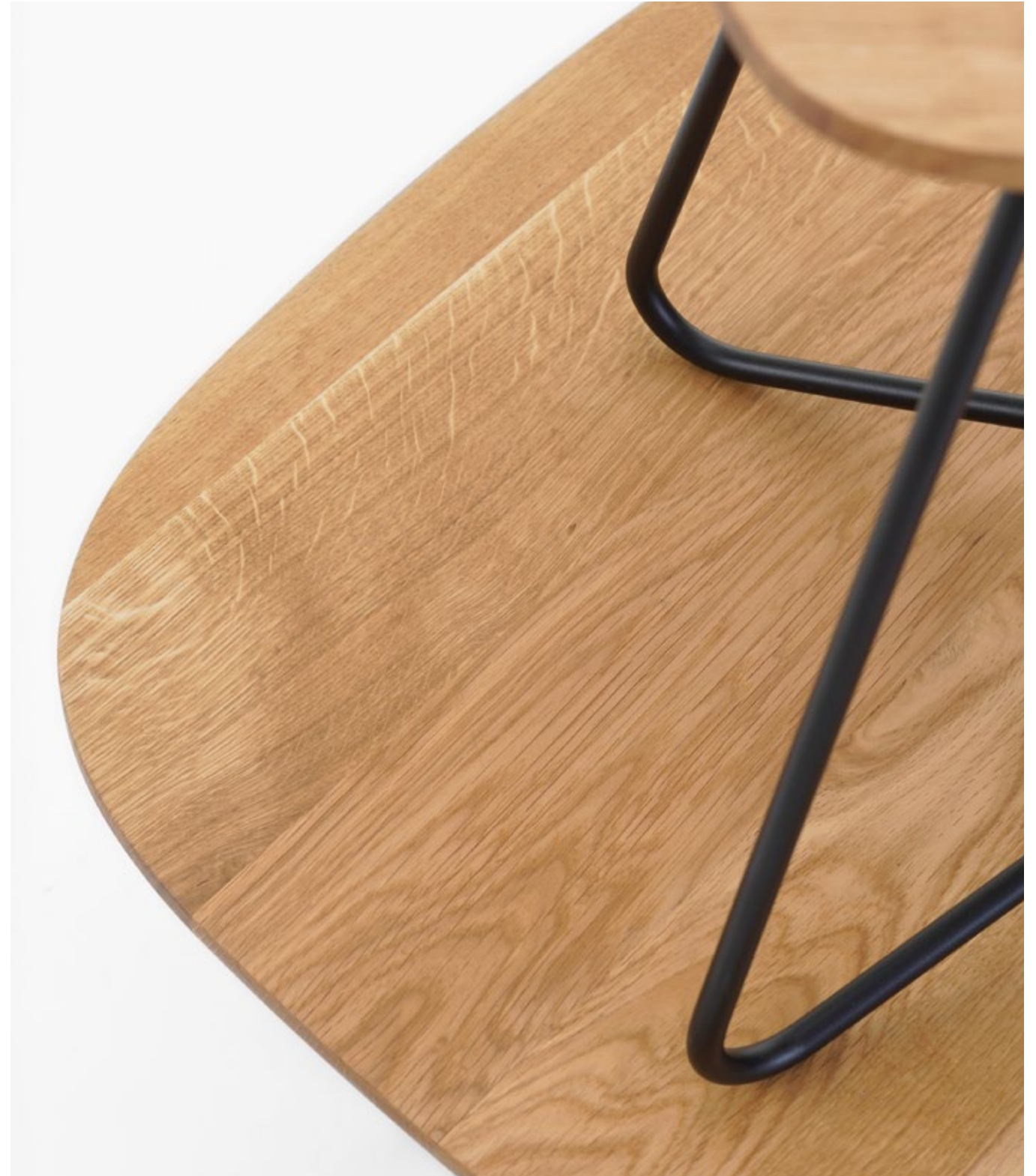



Crafted from high-quality materials such as solid oak, medium-density fiberboard, or compact laminate, these tables are designed for durability while maintaining a sleek and modern look. Their intricately interwoven metal legs provide stability and contribute to an airy, lightweight appearance. The leg design perfectly complements Ruvo chairs, creating a cohesive and harmonious aesthetic.



Whether placed in a living room, office, lounge area, or modern café, Ruvo low tables help create a thoughtfully curated atmosphere tailored to contemporary lifestyles. With Ruvo chairs, they enhance the overall ambiance, seamlessly blending design and functionality for a sophisticated and inviting space.

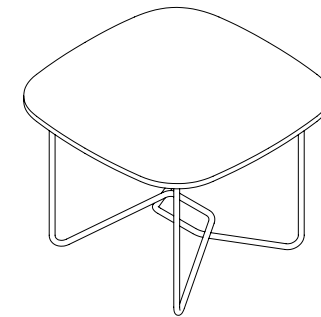

Ruvo

Ruvo low tables boast an elegant and contemporary design, available in three sizes and heights to suit various needs and interior styles. Their sophisticated aesthetics and soft-touch finish engage multiple senses, delivering visual appeal and a refined tactile experience.

CATEGORY Coffee table
SUITABILITY Indoor

TECHNICAL SPECIFICATIONS

TABLETOP / Fenix, matt acrylic varnish or natural oil. Refer to materials guide for more information.

BASE / Matt powder coated steel bars

Table high

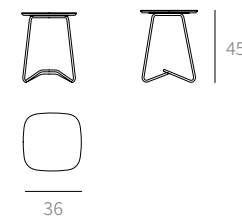

Table medium

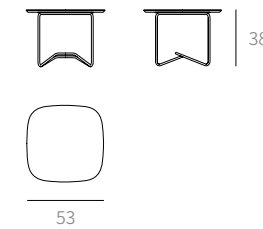
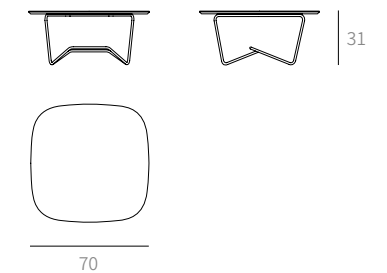

Table low



Cot
Cot Backrest
Cot Wood
Kanap
Nauvik
Bolta
Bolta Lounge
Ruvo
Ruvo Jiha
Ruvo X
Svib
Dika
Mustra

Sechia

Ala
Ala Outdoor
Ala Office
Ala Conference
Ala Bar
Jaro bar & bistro
Ruvo

Kier collection

Sfumato
Aman Taman
Duja

Taraba
Eho
Kosir
Skupa

04

Bedroom



Kier collection







An integrated mirror with a unique addition to the design enhances utility and aesthetic appeal. Ideal for entryways, bedrooms, or dressing areas, the Kier Coat Stand brings organization and style into any space.

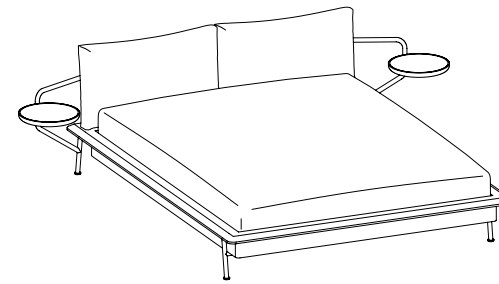

Kier BED WITH NIGHTSTANDS

The Kier Bed is a refined and functional centrepiece that embodies simplicity and elegance. Its sleek black steel frame provides a strong yet lightweight structure, softened by the warmth of natural wood details.

CATEGORY Bed
SUITABILITY Indoor

TECHNICAL SPECIFICATIONS

HEADBOARD / Plywood and sponge. Fabric or leather upholstery. Refer to materials guide for more information.

BED FRAME / Solid oiled oak, matt lacquered MDF

BASE / Matt powder coated metal tubes and plates

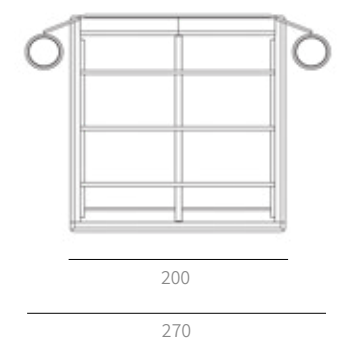
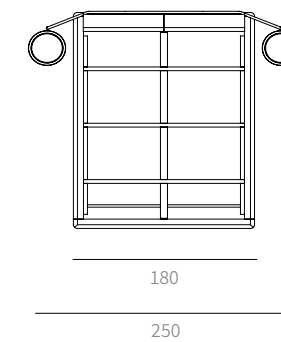
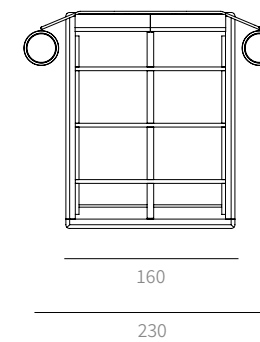
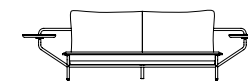
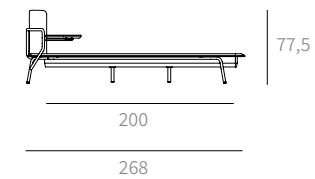

Kier

VANITY
TABLE

Blending versatility with minimalist design, the Kier Vanity Desk is a compact yet striking workspace. The black steel frame and natural wood top create a balanced contrast, while the subtly integrated drawer provides discreet storage for essentials.

CATEGORY Table with mirror
SUITABILITY Indoor

TECHNICAL SPECIFICATIONS

TABLETOP / Solid oiled oak solid wood with drawer in matt lacquered MDF. Refer to materials guide for more information.

BASE / Matt powder coated steel plate and tube

MIRROR / Mirror and lacquered MDF

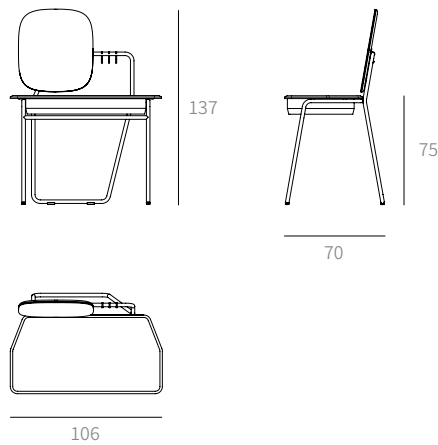
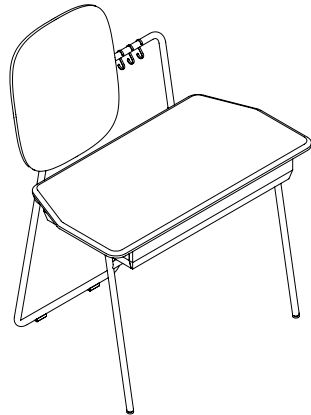

Kier

COAT
STAND

The Kier Coat Stand is a thoughtfully designed storage solution that merges elegance with practicality. Featuring a lightweight steel frame, it offers ample space for hanging clothes while maintaining a visually open and airy presence.

CATEGORY Coat stand
SUITABILITY Indoor

TECHNICAL SPECIFICATIONS

BASE + HOOKS / Matt powder coated metal tube and plate

MIRROR / Mirror and lacquered MDF

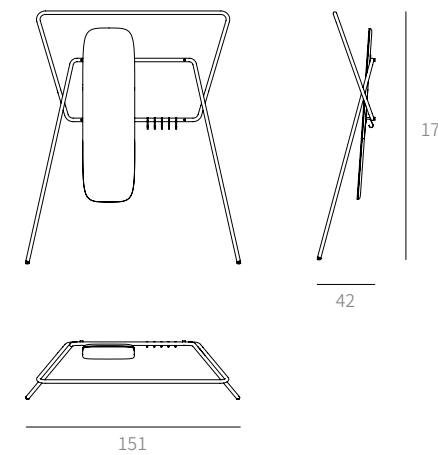
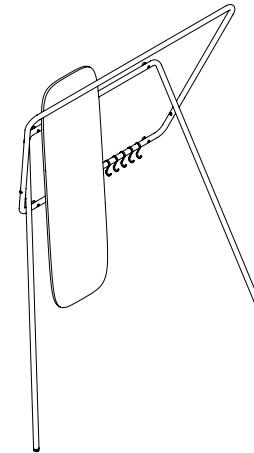

Cot
Cot Backrest
Cot Wood
Knap
Nauvik
Bolta
Bolta Lounge
Ruvo
Ruvo Jiha
Ruvo X
Svib
Dika
Mustra

Sechia

Ala
Ala Outdoor
Ala Office
Ala Conference
Ala Bar
Jaro bar & bistro
Ruvo

Kier collection

Sfumato
Aman Taman
Duja

Taraba
Eho
Kosir
Skupa

05

Storage



**BIGSEE
PRODUCT DESIGN
AWARD 2019
WINNER**



Sfumato

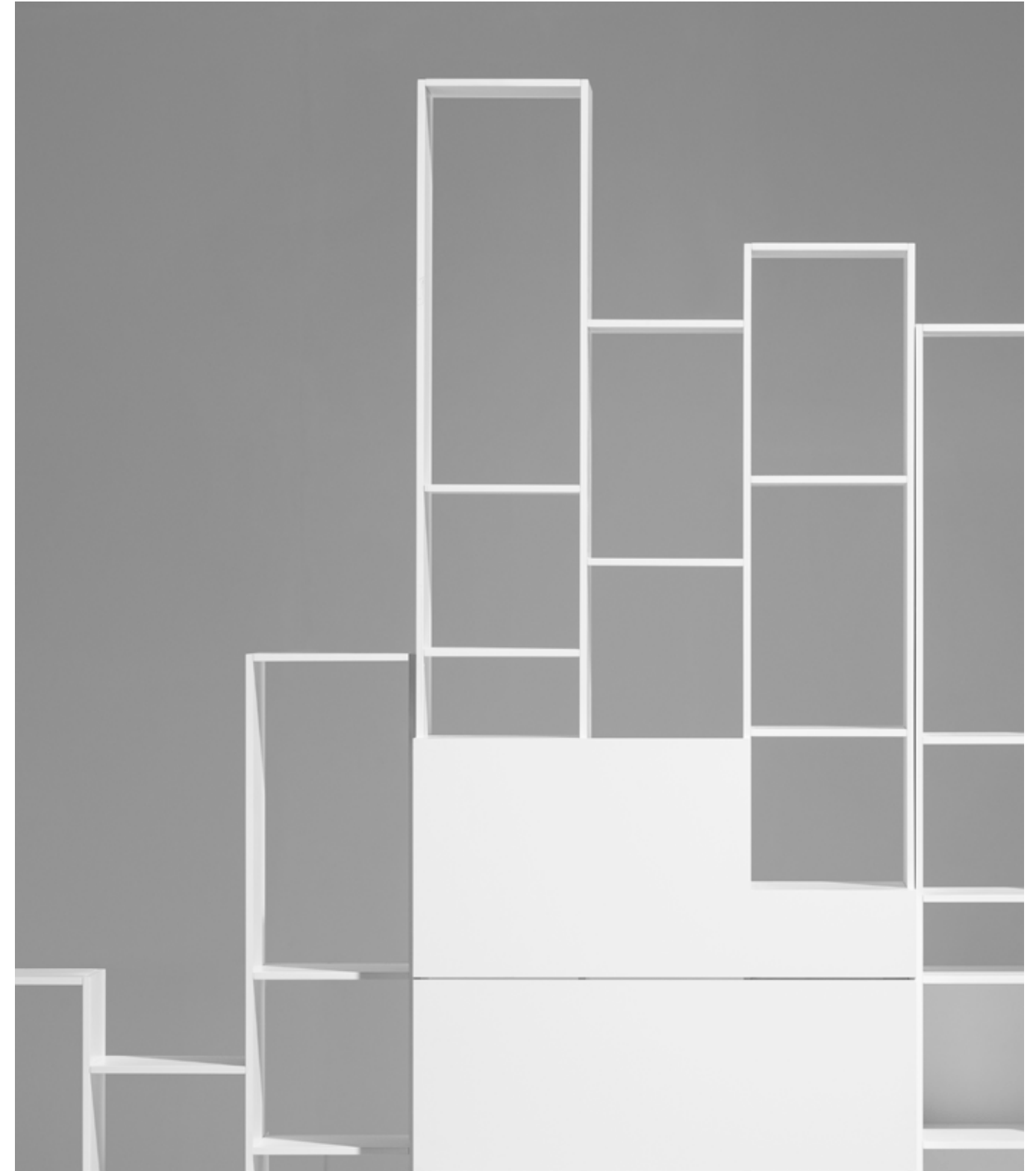





Sfumato

The balance between open and closed sections creates visual harmony, while the asymmetrical arrangement adds a touch of modernity and dynamism. Crafted with precision and high-quality materials, the system ensures durability and adaptability to any interior.

CATEGORY Storage units
SUITABILITY Indoor

TECHNICAL SPECIFICATIONS

BODY / Matt lacquered MDF. Refer to materials guide for more information.

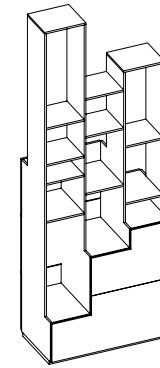

Modul A

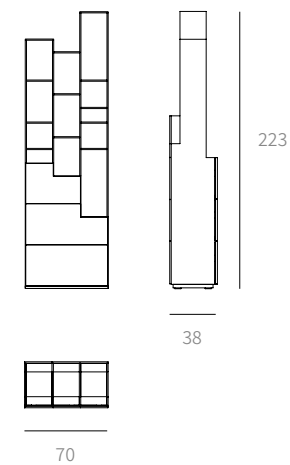

Modul B

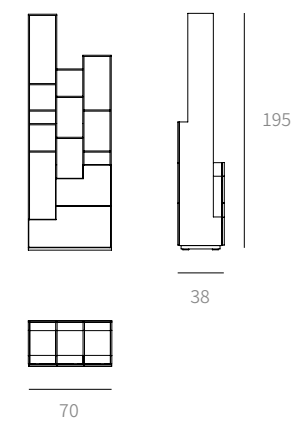

Modul C

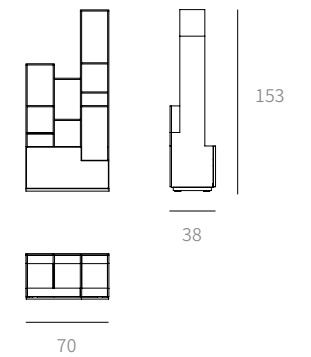



Aman Taman is a genuinely unique cabinet that breathes with interior. In design, true brilliance lies in adaptability, the ability to transform without losing the essence. Aman Taman embodies this philosophy, a cabinet that seamlessly integrates into any space, evolving with your needs while maintaining its refined simplicity. It is a balance of form and function, a design that instils confidence in its practicality and aesthetic appeal, making it a perfect fit for any environment.

Aman Taman





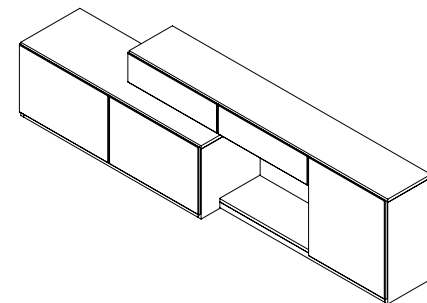

Aman Taman

Designed to hold what matters: books, keepsakes, and quiet moments, it offers practicality and aesthetic harmony. Subtle yet undeniable, its presence is rather than seen; it feels like a well-placed pause in music, like the perfect play of light in a room, like home.

CATEGORY Modular storage unit
SUITABILITY Indoor

TECHNICAL SPECIFICATIONS

BODY / Matt lacquered MDF. Refer to materials guide for more information.

Retracted

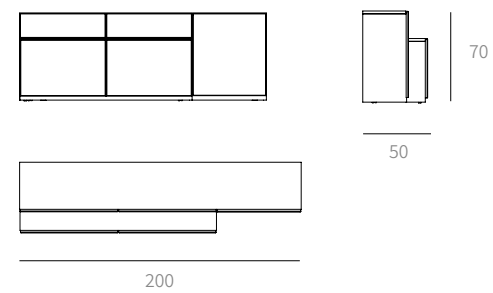

Extended

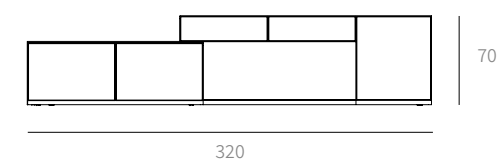



Two separate modules, which slide underneath each other, create a playful cabinet named Duja. When the modules are stacked on top of each other, they form a monolithic volume, but when they are spread apart, their shapes become eccentric and elegant. Regardless of the wall length, the modules provide the optimal length for any composition.

Duja









The cabinet features a discreet design and the option to choose different colors, making it a perfect addition to any home. Its adaptability allows for various arrangements, from minimalist to sophisticated, easily fitting into different interior styles. The modules are not only functional but also add aesthetic value to the space.





Duja A & B

The combination of practicality and aesthetics makes this cabinet unique. Its ability to adapt to different needs and spaces makes it an ideal choice for modern homes. Whether used for storage or as a decorative element, the cabinet will surely attract attention and become a favorite part of your interior.

CATEGORY Modular cabinets

SUITABILITY Indoor

TECHNICAL SPECIFICATIONS

BODY / Matt lacquered MDF. Refer to materials guide for more information.

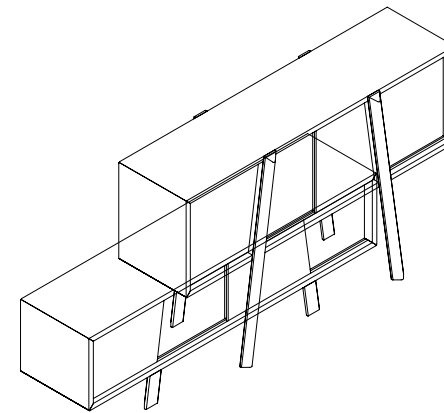

Modul A

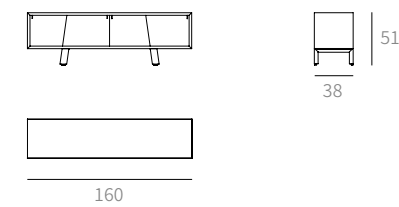

Modul B

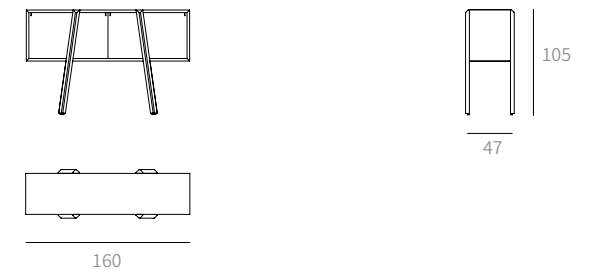

Combination (retracted)

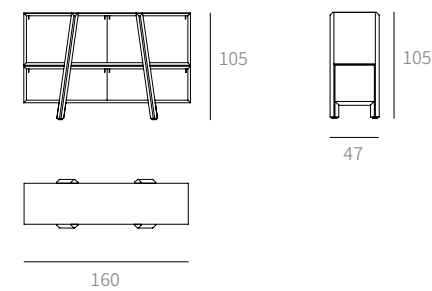

Combination (extended)

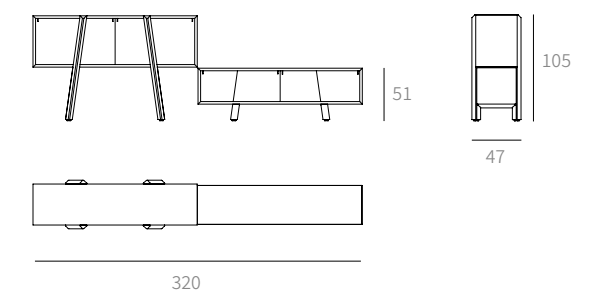

Cot
Cot Backrest
Cot Wood
Knap
Nauvik
Bolta
Bolta Lounge
Ruvo
Ruvo Jiha
Ruvo X
Svib
Dika
Mustra

Sechia

Ala
Ala Outdoor
Ala Office
Ala Conference
Ala Bar
Jaro bar & bistro
Ruvo

Kier collection

Sfumato
Aman Taman
Duja

Taraba
Eho
Kosir
Skupa

06

Accessories

 **BIGSEE
PRODUCTDESIGN
AWARD 2019
WINNER**

 **BIGSEE
WOOD
AWARD 2019
WINNER**



Taraba







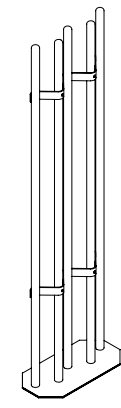

Taraba

Its simple yet sophisticated form fits perfectly into contemporary interiors while also bringing the warmth and character of traditional materials. Taraba will give any space a unique touch, whether used as a space divider, decorative element, or functional addition.

CATEGORY Divider
SUITABILITY Indoor

TECHNICAL SPECIFICATIONS

STICKS / Solid oiled oak. Refer to materials guide for more information.

BASE + CONNECTORS / Matt powder coated metal tube and plate

UPHOLSTERY / Fabric

OPTIONS

Matt powder coated steel hooks

Modul A

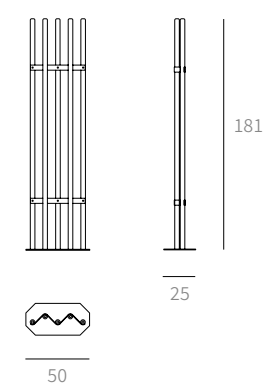

Modul B

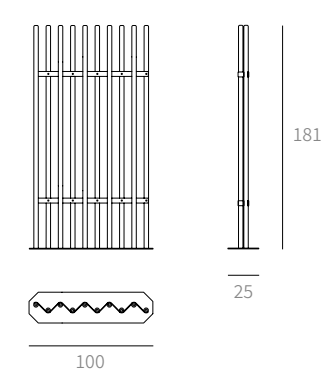

Modul C

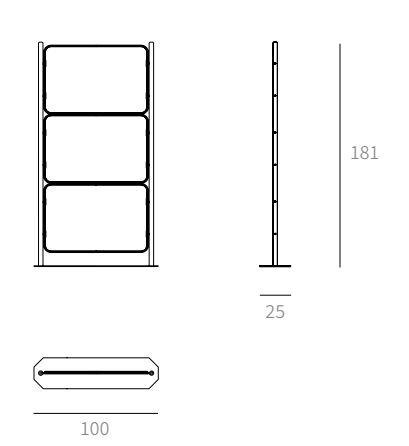

 **BIGSEE
WOOD
AWARD 2019
WINNER**



Eho



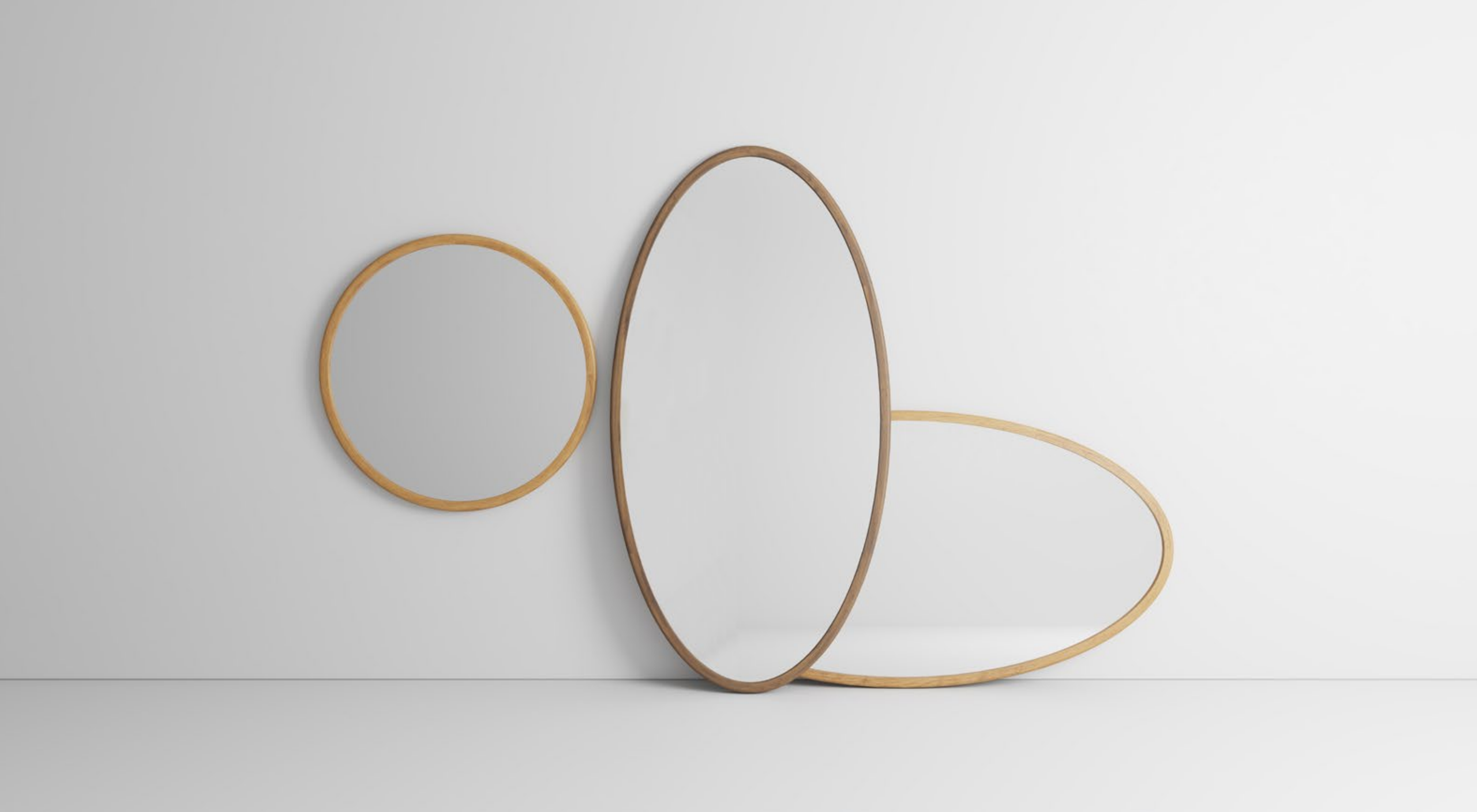

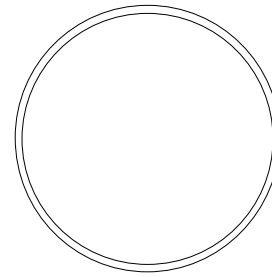

Eho

The word "echo" signifies the reflection of sound, creating its repeated experience. This idea of repetition and reflection inspired the creation of this mirror, which reflects not only the image but also the essence of space, light, and atmosphere.

CATEGORY Accessories

SUITABILITY Indoor

TECHNICAL SPECIFICATIONS

FRAME / Am. walnut or oak solid wood, matt acrylic varnish or natural oil. Refer to materials guide for more information.

MIRROR / Glass mirror

SUB-CONSTRUCTION / Plywood

Versatile and adaptable to various spaces, Eho brings functionality and an artistic accent. Its refined aesthetics and carefully designed details make it an element that connects the past and present, design and atmosphere, sound and image, bringing a sense of harmony and subtle beauty to any space.

Round

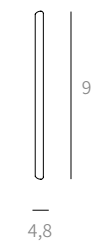
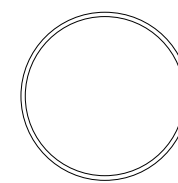

95

Oval

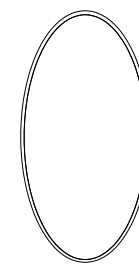

95



Kosir





Kosir draws inspiration from simplicity and functionality, combining precisely shaped metal with a dynamic yet stable form. Its silhouette, shaped by bending at a 90-degree angle, brings a playful balance between sculptural aesthetics and practical use.

Kosir

With its clean lines and thoughtful construction, Kosir easily fits into different environments, becoming an unobtrusive yet striking element that connects aesthetics and practicality.

CATEGORY Side table
SUITABILITY Indoor

TECHNICAL SPECIFICATIONS

BASE AND TABLETOP / Matt powder coated steel

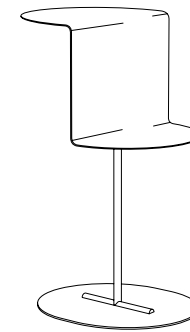

Kosir Z

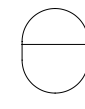
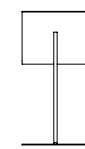

32

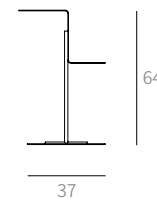

Kosir G

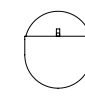
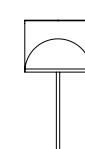

32

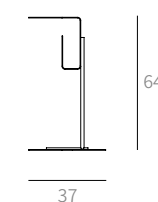

Kosir C

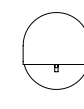
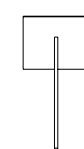

32

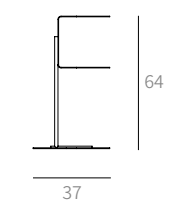



The interplay of these materials and forms enhances functionality and aesthetics, with the pouffes fitting snugly within the tables' main frame. This thoughtful design not only maximizes space efficiency but also encourages interaction and flexibility in use.

Skupa



Thinking of space as a geographical terrain where the interactions of its inhabitants are in a constant state of flux, Skupa is a collection of pouffes and side tables that evoke the image of an archipelago, continuously adapting to change when viewed from afar. Designed to reflect movement and balance, the collection creates a dynamic landscape within any interior, where each piece can stand alone or form part of a larger composition. Its modular nature allows users to reconfigure the elements effortlessly, making it suitable for evolving environments such as lounges, offices, or hospitality settings.



With the potential to create diverse arrangements, Skupa adapts to the needs of any space, whether through individual standalone pieces or interconnected clusters. The collection offers endless possibilities for customization, allowing users to experiment with layouts that suit their preferences. Whether arranged to foster collaboration in communal areas or to create intimate corners for relaxation, Skupa transforms the perception of furniture as static objects into an ever-evolving landscape that responds to the dynamics of its surroundings.

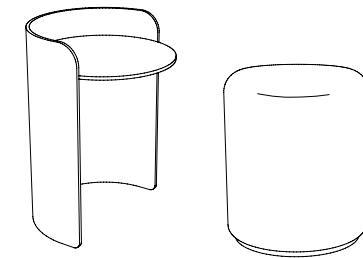

Skupa A

Skupa harmoniously combines contrasting elements—soft, inviting pouffes with structured, minimalistic side tables. The upholstered pouffes, available in various shapes and dimensions, provide comfort and warmth, while the sleek outlines of the metal or plywood side tables introduce structure and definition.

CATEGORY Side table and pouff
SUITABILITY Indoor

TECHNICAL SPECIFICATIONS

TABLE / Am. walnut or oak veneer, matt acrylic varnish or natural oil. Refer to materials guide for more information.

POUFF / Fabric or leather upholstery

POUFF SUB-CONSTRUCTION / Plywood, solid slats

Skupa A table

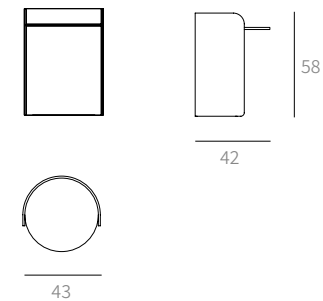

Skupa A pouff

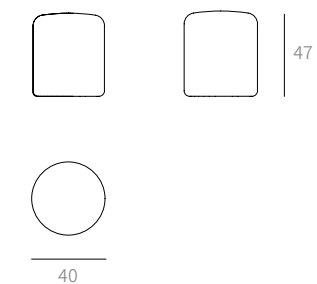

Skupa B

Skupa harmoniously combines contrasting elements—soft, inviting pouffes with structured, minimalistic side tables. The upholstered pouffes, available in various shapes and dimensions, provide comfort and warmth, while the sleek outlines of the metal or plywood side tables introduce structure and definition.

CATEGORY Side table and pouff
SUITABILITY Indoor

TECHNICAL SPECIFICATIONS

TABLE / Am. walnut or oak veneer, matt acrylic varnish or natural oil. Refer to materials guide for more information.

POUFF / Fabric or leather upholstery

POUFF SUB-CONSTRUCTION / Plywood, solid slats

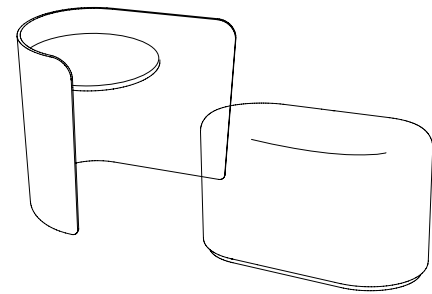

Skupa B table

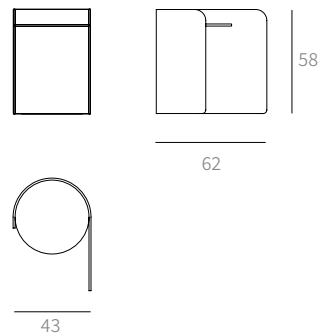

Skupa B pouff

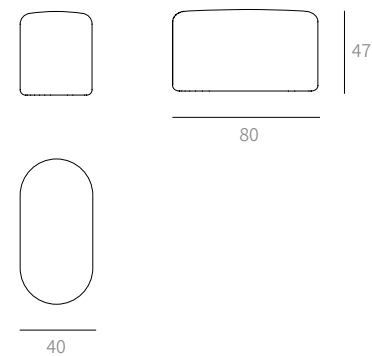

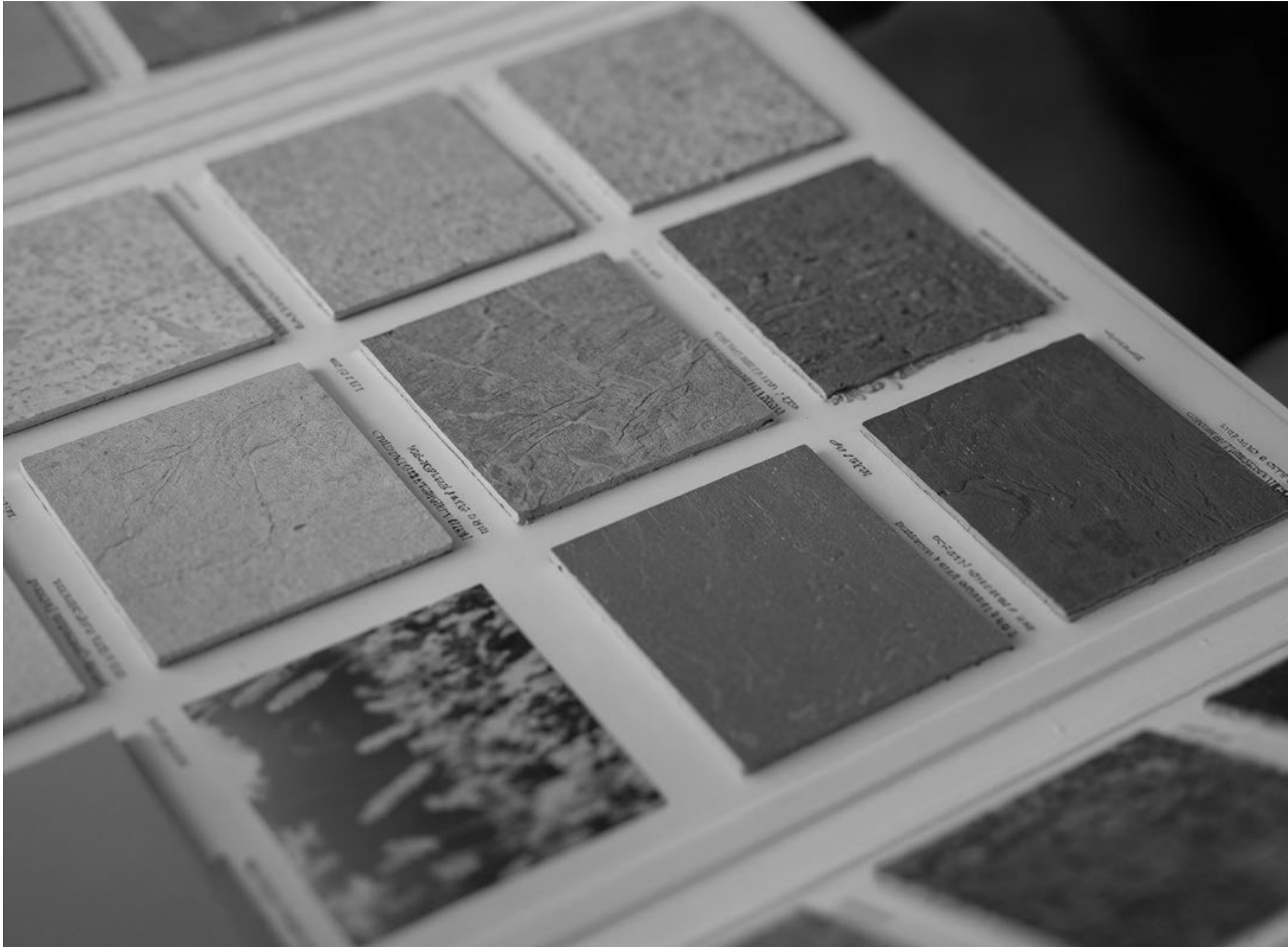

Materials

We prioritize innovation and collaborate with leading experts to continuously explore new techniques and materials. The choice of materials is a key focus in our design process, where we carefully consider each material, like wood, metal and fabrics. Along with factors like appearance, feel, and durability, we also assess the sustainability and lifecycle of each material.

MORE INFORMATION ON NEXT PAGES ABOUT

FABRICS (Quest, Rivet, X2, Main line Plus, Replay, Main line Flax, Main line Flax, Monochrome Sett, Blazer, Panda)

MDFs

MATERIAL FINISHES (Metal, Solid wood, Veneer, Compact, Fenix)

OUR DESIGNERS

Fabric

Quest

Fabric

Rivet

camira

camira

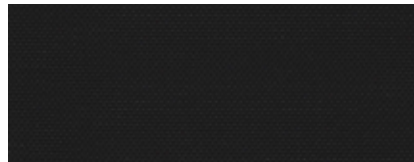

QUE01-Depth



QUE02-Fossil



QUE03-Barnacle

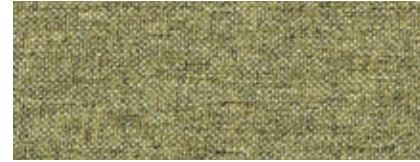

EGL05-Alloy



EGL08-Fuse



EGL16-Prime



QUE07-Ripple



QUE09-Limpet



QUE12-Tide



EGL12-Forge



EGL20-Tensile



EGL19-Chromoly



QUE13-Sea Grass



QUE18-Abalone



QUE21-Beach Comber



EGL25-Cast



EGL24-Crucible



Rivet-EGL27-Hammer



QUE22-Salt



QUE23-Cockle



QUE26-Shrimp



EGL32-Deep Clay



EGL36-Otter



EGL33-Woodrose

Fabric

X2

camira

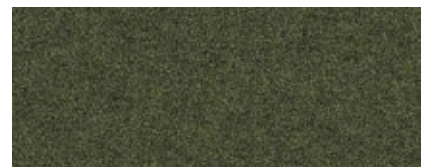

AK004-Equation

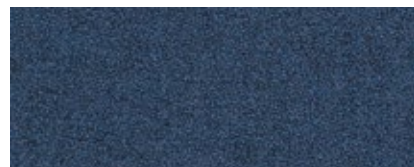

AK046-Rule

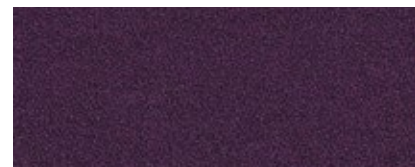

AK011-Median



AK006-Value



AK014-Multiply



AK012-Add



AK016-Percentage

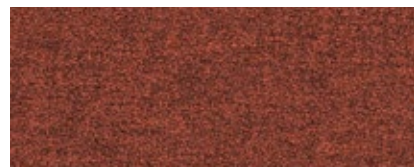

AK015-Divide



AK050-Theory



AK018-Arithmetic

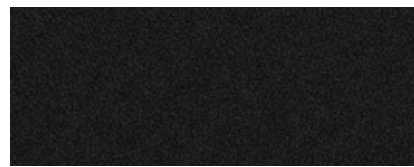

AK049-Diameter



AK020-Number

Fabric

Main Line Plus

camira



IF000-Charcoal



IF276-Girder



IF111-Clipper



IF020-Royal



IF241-Tuscany



IF084-Juniper



IF027-Wedgwood



IF231-Mermaid



IF142-Marmalade



IF147-Penstemon



IF272-Matador



IF058-Lead

Fabric

Replay

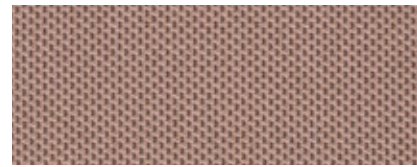

REP15-Pull



REP11-Freestyle



REP18-Roll



REP12-Motion



REP24-Workout



REP17-Lift



REP01-Flex



REP25-Jump



REP03-Athletic



REP27-Sport



REP33-Climb



REP29-Twirl

camira

Fabric

Main Line Flax



MLF02-Archway



MLF43-Alperton



MLF10-Newbury



MLF07-Kensington



MLF22-Westminster



MLF09-Monument



MLF25-Bethnal



MLF57-Moorgate

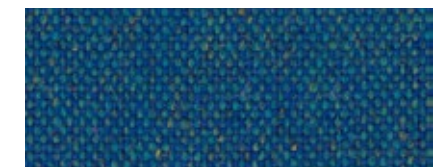

MLF34-Pimlico



MLF63-Shadwell

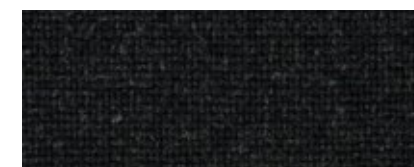

MLF28-Edgware

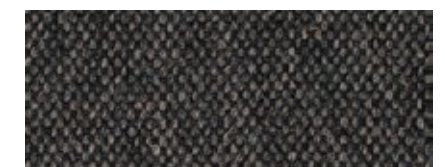

MLF16-Temple

camira

Fabric

Main Line Twist

camira



MLT01-Fold

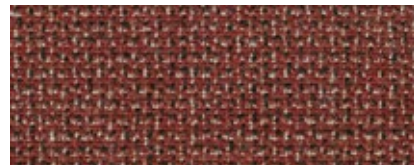

MLT02-Cone



MLT04-Yarn

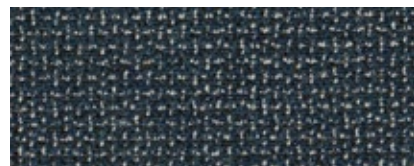

MLT05-Fibre



MLT07-Scour



MLT06-Crimp



MLT09-Creel

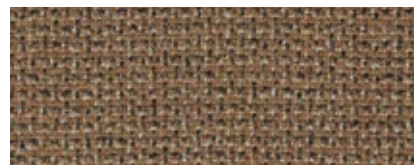

MLT10-Ply



MLT13-Hank

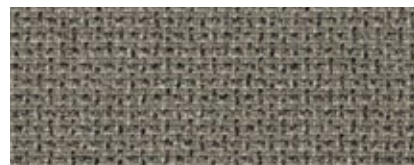

MLT12-Spin



MLT14-Micron



MLT15-Slub

Fabric

Monochrome Set

camira



MLB01-Sett #5 MLB01



MLB02-Sett #5 MLB02



MLC01-Sett #3 MLC01



MLC02-Sett #3 MLC02



MLD01-Sett #4 MLD01

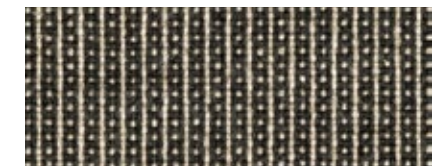

MLD02-Sett #4 MLD02

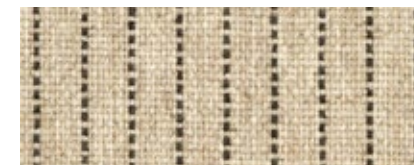

MLE01-Sett #2 MLE01



MLE02-Sett #2 MLE02



MLG01-Sett #1 MLG01



MLG02-Sett #1 MLG02



MLJ01-Sett 7 MLJ01



MLH01-Sett #6 MLH01

Fabric

Blazer

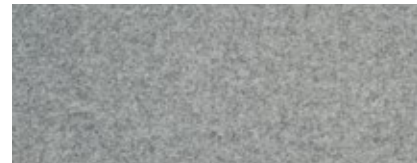

CUZ1E-Surrey



CUZ3R-Stowe



CUZ3T-Earlscliffe



CUZ4U-Uplands



CUZ1R-Plymouth

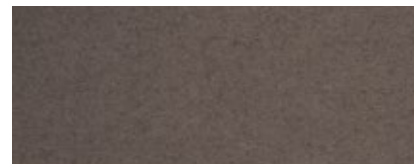

CUZ31-Trevelyan



CUZ3M-Lucton



CUZ3V-Sidcot

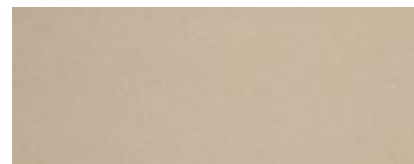

CUZ47-Fairfield

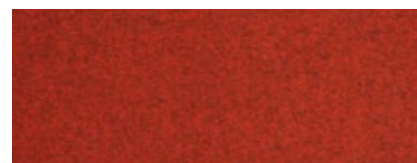

CUZ90-Edge Hill

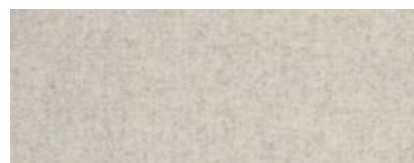

CUZ2Q-Dartmouth



CUZ30-Silcoates

Leather

Panda

camira



179

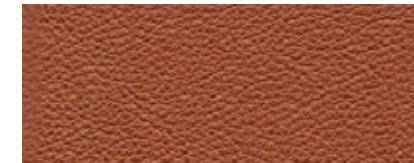

165



152

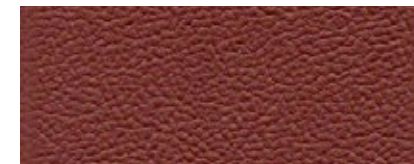

166



161

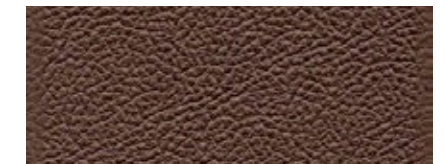

174



186



168



185

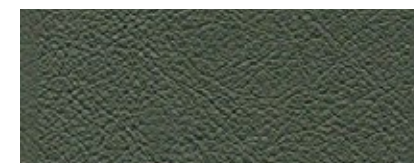

159

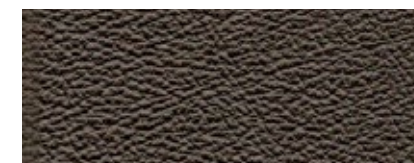

167



170



S 5540-G50Y



S 3030-G50Y



S 1515-G40Y



S 8505-G80Y



S 5005-G80Y



S 2005-G80Y



S 8010-G90Y



S 4010-G90Y



S 2010-G90Y



S 5040-B10G



S 4020-B10G

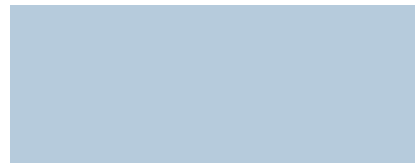

S 1515-R90B



S 3060-Y80R



S 2030-Y90R

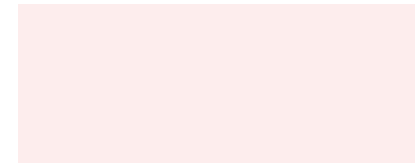

S 0507-R



S 7020-Y70R



S 4020-Y70R

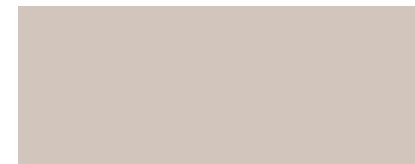

S 2005-Y60R



S 9000-N



S 8500-N

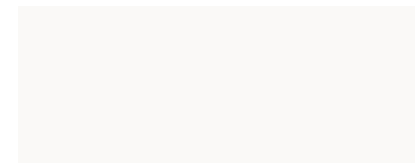

S 0500-N

MDF

Our MDF collection offers a wide range of color options, ideal for modern furniture design. Made from engineered wood fibers, MDF provides exceptional durability and a smooth surface, while maintaining a lightweight construction.



FENIX 0720 Nero Ingo



FENIX 0751 Rosso



FENIX 0773 Verde Brac



FENIX 0724 Grigio Bromo



FENIX 0770 Rosso Askja



FENIX 0794 Verde Kitami



FENIX 0752 Grigio Antrim



FENIX 0790 Viola Orissa



FENIX 0032 Bianco Cos

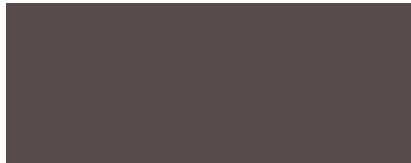

FENIX 0749 Cacao Orinoco



FENIX 0792 Blu shaba



FENIX 0717 Castoro Ottawa



FENIX 0754 Blu fes



FENIX 0748 Beige Arizona



FENIX 0771 Azzurro Naxos



FENIX 0773 Verde Comodorc

FENIX®

FENIX

Our FENIX collection features innovative nanotech surfaces, perfect for sophisticated and contemporary interiors. Resistant to scratches, fingerprints, and heat, FENIX combines aesthetic elegance with high performance and a soft-touch matte finish.



RAL 9005



RAL 7016



RAL 9010

METAL



SOLID WOOD OILED AMERICAN WALNUT



SOLID WOOD OILED OAK

SOLID WOOD

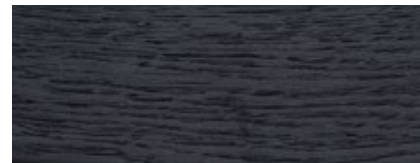

BLACK STAINED OAK VENEER

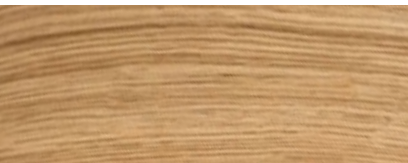

LACQUERED OAK VENEER



LACQUERED AMERICAN WALNUT VENEER

VENEER

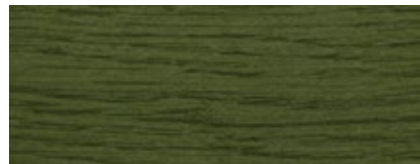

LACQUERED COLORED VENEER - RAL



LACQUERED COLORED VENEER - NCS

COMPACT

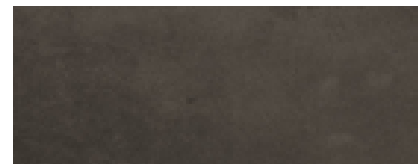

PRADO AGATE GREY

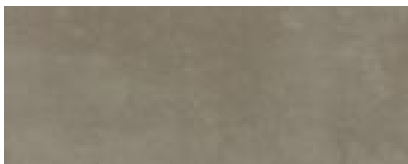

PRADO ALU GREY

Material finish

Our furniture collection includes solid wood from Slavonian oak, known for its durability and strength, as well as American walnut for a sleek, refined look. We also use veneer to construct furniture pieces, ensuring a high-quality, lightweight build. Additionally, metal is typically used for product bases, while compact plates are used for tabletops, ensuring durability and stability.

Designers

Nunc features designs by young regional designers and has won several prestigious awards. Nikola Radeljković, a well-known designer from the Numen/ForUse collective, plays a key role as creative director, guiding the brand's development. Nunc's designs blend contemporary interpretations of traditional Slavonian materials and craftsmanship, showcasing the brand's commitment to high-quality, flexible, and innovative design.

DESIGNERS

Ivana Josimovska

Katerina Trpkovska / Rinocca

Lea Aviani

Filter

Nataša Njegovanović

Regular Company

Riccardo Carli

Vladimir Madunić / ABC design

Studio Lav

Neisako

Studio Ru:t

Tak Kolektiv

Simon Pengelly



ART DIRECTOR

Nikola Radeljković



Ivana Josimovska



Katerina Trpkovska / Rinocca



Lea Aviani



Filter



Nataša Njegovanović



Regular Company



Riccardo Carli



Vladimir Madunić / ABC design



Studio Lav



Neisako

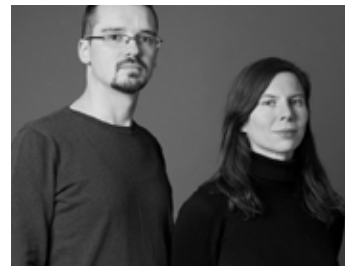

Studio Ru:t



Tak Kolektiv



Simon Pengelly





The immense cultural heritage embodied in Nunc's collection has been our drive over the years to start translating from the then to the now.

Our roots lie in solid wood and wood-based board furniture, built on decades of experience combining traditional wood-working with refined industrial production.

Nunc is based in Đakovo, in the heart of Slavonia, Croatia's fertile and culturally rich region, surrounded by the Danube, Drava, and Sava rivers.

Our production facilities stretch over 3,287 m², consisting of a 1,809 m² production and storage building and a 1,478 m² economic yard, providing the space and infrastructure to create contemporary furniture deeply rooted in local tradition.

Nunc's design language emerges from the intersection of diverse cultural influences, Central European clarity, Mediterranean warmth, and traces of Ottoman ornamentation.

This blend gives rise to a unique aesthetic that resonates with the layered history of the region.

The vast Slavonian landscape, generous and elemental, reflects in our work through the textures, tones, and natural materials we use, especially the revered Slavonian oak.

We see design as a form of storytelling.

Our products balance rational geometry with warmth and tactility, creating pieces that belong equally in urban interiors and traditional rural homes.

Each name in our collection draws from the regional vocabulary, an organic fusion of Croatian, Serbian, German, Hungarian, and Turkish expressions, capturing the everyday poetry of life in Slavonia.

Nunc is a vision of progress rooted in place.

Our furniture carries the spirit of a region where the line between interior and exterior life is fluid, where heritage and modernity coexist.

It is here, in Đakovo, that we shape each piece, bridging the then and the now.

About us

The story of the Slavonian oak is also one of craftsmanship.

Generations of skilled hands have passed down techniques that bring out the best in each piece of wood.

In our factory, traditional knowledge meets modern technology, allowing us to work with the material respectfully, preserving its integrity while unlocking its potential through contemporary forms.

Slavonian oak's natural resistance and warm, golden hues make it an ideal companion for modern living.

But beyond aesthetics, its presence carries something deeper, a sense of rootedness, resilience, and quiet dignity.

Every grain tells a story, not just of the tree itself, but of the land, people, and time that shaped it.

In choosing solid wood from Slavonia, Nunc chooses continuity, a link between past and present, forest and home, nature and design.



Wood resource



The rhythm of the sawmill is also one of precision craftsmanship.

Teams of experienced operators oversee processes that transform raw logs into refined structural elements and engineered surfaces built to last.

Within our facility, tested practices integrate with advanced machinery, enabling us to handle each board responsibly, maintaining its strength while shaping its performance for contemporary applications.

Drying cycles and precise cutting methods make it a reliable foundation for modern construction and systems.

Beyond production, the workflow reflects continuity, discipline, and a commitment to material intelligence and operational clarity.

Every plank carries a record of processing, from log intake to grading, optimization, and final dimensional calibration within controlled environments fully.

By sourcing locally and machining responsibly, Nunc maintains a connection between resource and result, industry and habitat, innovation and tradition today.

Sawmill

Crafted from high-quality, kiln-dried wood, each plank is carefully selected and treated to preserve its natural grain and texture.

The raw edges and organic imperfections add a rugged, authentic character that celebrates the inherent beauty of timber.

Ideal for use in furniture making, wall paneling, or bespoke interior features, these boards offer exceptional warmth and structural integrity.

Every piece is the result of precise craftsmanship, cut thick for durability, air-dried for stability, and finished to highlight its unique personality.

Whether featured in modern industrial spaces or rustic-inspired interiors, this wood serves not just as a material, but as a statement.

Engineered for comfort and support, the gently contoured backrest provides ergonomic benefits, while the spacious seat ensures a relaxed sitting experience.

The sturdy metal legs are reinforced with crossbars that add extra stability and also serve as a convenient footrest. This thoughtful design makes it ideal for extended use.



Production elements



Behind every piece of furniture, stands a team of skilled individuals, whose passion and expertise shape each detail with care and precision.

Our production process is not just a matter of machines and materials, but of hands that understand wood, eyes that notice every curve, and minds that never compromise on quality.

Each component is touched by the dedication of craftspeople, who take pride in their work, from designers, engineers, and machinists, to finishers and quality control specialists.

Their deep knowledge, gained through years of experience, is what transforms raw materials into functional beauty.

In our workshops, collaboration is key. Whether it's adjusting a mold by hand, inspecting every layer of finish, or ensuring every curve is ergonomically perfect, our team works with unwavering focus, and mutual respect.

This human touch is what gives our furniture its soul.

It's not just production, it's a craft, built with intention, patience, and pride, by people who care.

Production

What begins with raw materials and skilled hands, culminates in a refined product, that brings spaces to life.

Each finished piece reflects the harmony between form and function, a balance achieved through thoughtful design, meticulous craftsmanship, and a deep respect for the material.

The final product is not just a chair, but a statement of intention. With soft, ergonomic backrests, warm wood accents, and durable, stable bases, these pieces are created to support both body and atmosphere.

Whether placed in a conference room, a hospitality setting, or a curated interior, they invite comfort, focus, and conversation.

At the heart of it all is a commitment to people, those who create, and those who sit.

The result is furniture that not only performs, but inspires.



Final products



In the final stage of production, precision meets purpose.

Each product is carefully assembled by skilled hands, ensuring that every joint is secure, every surface aligned, and every component ready for use.

Our team works with attention to detail, driven by the knowledge that this is the moment where form and function come together.

Packaging is more than protection, it is a continuation of our care.

Every item is wrapped, cushioned, and boxed to preserve its integrity during transport, while maintaining the aesthetic standards we value.

From workshop to warehouse, and finally to your space, each step reflects our respect for the product, and for the people who will use it.

It is the quiet craftsmanship behind the scenes, patient, precise, and essential.

Packaging

From our production facility, our furniture begins its journey to destinations across Europe, Asia, North America, and beyond.

Every shipment represents the final step of a process rooted in precision, dedication, and care.

Once the product is assembled, inspected, and carefully packaged, it enters a logistics chain managed by experienced professionals, ensuring that each item reaches its destination safely, and on time.

Our team works closely with trusted freight carriers, coordinating road, sea, and air transport depending on the scale and urgency of the delivery.

Full truckloads, mixed cargo, and overseas containers are loaded with attention to detail, making sure that every box is protected, labeled, and traceable.

Export documentation, customs procedures, and international regulations are handled with accuracy, so our clients can rely on a smooth and transparent process.

Because for us, delivery is not an afterthought, it is an essential part of the story.

It is the moment when everything comes together, when craftsmanship travels, and when design finds its new home.



Global Logistics

Impressum

NUNC'S DESIGN CURATOR: Nikola Radeljković
COPYWRITING: Dolores Grubeša
PHOTOGRAPHY: Pavel Posavec, Domagoj Kunić,
Dolores Grubeša
3D GRAPHICS: Emir Selimović, Dominik Žalac

Printed in 2026. in Zagreb

Nunc is registered trademark of Ancona Grupa,
Djakovo, Croatia.

Follow us!



**FACTORY AND
HEADQUARTERS**

Makarska ulica 5
31400 Đakovo, Croatia

SHOWROOM

Gajeva ulica 21
10000 Zagreb, Croatia

info@nunc.design
www.nunc.design